

Targeted Performance: Thermal Energy Demand Intensity (TEDI)

Relative Performance: ASHRAE 90.1

Appendix G Performance Rating Method



2023 Massachusetts Commercial Stretch Code

Christina LaPerle PE, BEMP, CPHC®, CEM, CBCP

Maria Karpman LEED AP, BEMP, CEM

www.karpmanconsulting.net

WE ARE MASS SAVE®:



Logistics

Audio Settings

- **If you can't hear anything right now or you're having trouble with your audio**, you may select "Phone call" in the Audio portion of the control panel. Dial the number and enter the access code.

Handouts

Recordings

- This webinar is being recorded.

Polls

- You may have to exit "Full Screen Mode" for Polls

Questions

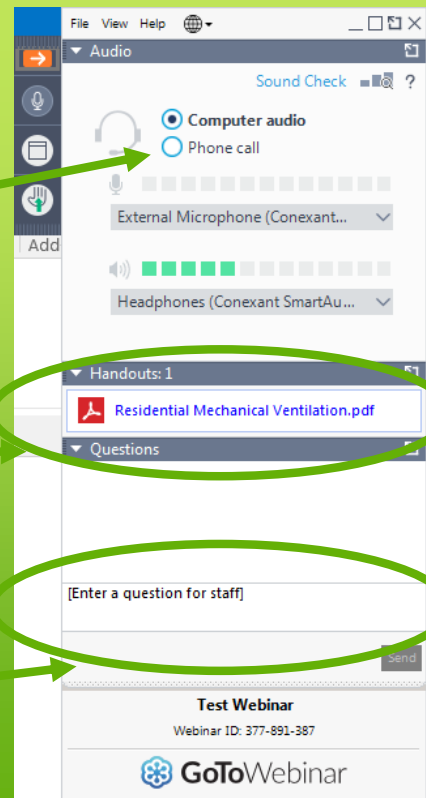



Together, we make good happen for Massachusetts.

Your local electric and natural gas utilities and energy efficiency service provider are taking strides in energy efficiency: Berkshire Gas, Cape Light Compact, Eversource, Liberty, National Grid and Until.

As one, we form Mass Save®, with the common goal of helping residents and businesses across Massachusetts save money and energy, leading our state to a clean and energy efficient future.

WE ARE MASS SAVE®:



We Are Mass Save®



Presented by:

PSD



Moving Energy Efficiency Forward

We combine building science with technology to help utility companies, program implementers, and building performance professionals achieve energy savings.



Continuing Education

This webinar is approved for:

- 4-hour CSL CEU
- 4 AIA LU | HSW
- 4 CO CEU
- 4 BPI CEU

Everyone will receive a certificate of attendance via email.

Another 4 continuing education credits (CEUs) will be available to participants that also attend the second half of the webinar on **Thursday, September 26th from 10 AM - 12 PM and 1 PM – 3 PM.**

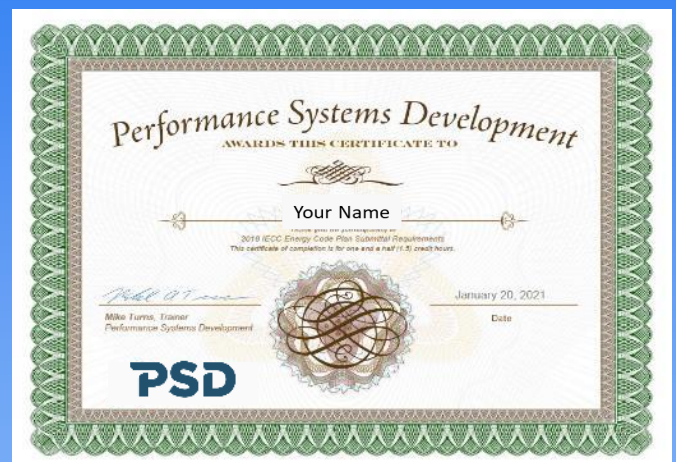

Learning Objectives

Understand the modeling requirements associated with the Targeted Performance Path and the Relative Performance Path for MA Commercial Stretch Energy Code compliance.

Comprehend the modeling requirements for special cases including core-and-shell projects and first-time tenant fit outs.

Develop a high-level, basic understanding of MA Stretch 2023 mandatory requirements and the types of 90.1 mandatory requirements that projects are required to comply with.

Understand how to use energy modeling results to extract the information needed to demonstrate compliance with the Targeted Performance Path.

Learn to establish model inputs for specific systems and components. For example, OA CFM rates for the Targeted Performance Path.

Articulate energy modeling requirements of the Relative Performance Path that deviate from the ASHRAE 90.1 Performance Rating Method.

List the documentation that must be submitted to code officials for projects following performance paths of compliance.

Learning Objectives Not Included

Understand MA Commercial Stretch Energy Code compliance options and their applicability to different building occupancy types.

Understand sample envelope designs that were shown to comply with TEDI.

Detailed understanding of Massachusetts Stretch 2023 mandatory requirements (these are at a high level in this 8-hour training but not covered in detail) and 90.1 mandatory requirements.

These objectives (with the exception of 90.1 mandatory requirements) are covered in the 4-hour training titled “MA Stretch Energy Code 2023 for Commercial Buildings: Targeted Performance (TEDI) and Relative Performance (90.1 Appendix G) Compliance Paths”

This 8-hour training is focused on energy modeling requirements.

Presented by Karpman Consulting

Karpman Consulting is a Registered Provider with The American Institute of Architects Continuing Education Systems.



KARPMAN
CONSULTING

Agenda



2023 Massachusetts Energy Code

Energy Modeling Requirements Applicable to the Relative and Targeted Performance Paths

Targeted Performance Path

- General concept
- Detailed modeling requirements with examples
- Extracting results from output reports to calculate TEDI
- Reporting requirements

Relative Performance Path

- General concept
- Modifications compared to 90.1 2019 Appendix G
- Detailed modeling w/examples (focused on commonly misunderstood areas and MA Stretch amendments)
- Reporting requirements

Overview of Available Trainings

Title	Target Audience	Topics covered
MA Stretch Energy Code 2023 for Commercial Buildings: Targeted Performance (TEDI) and Relative Performance (90.1 Appendix G) Compliance Paths (4 hours)	Code Officials & Modelers	<ul style="list-style-type: none">• Applicability• Overview of the modeling requirements• Special rules for additions, core-and-shell and retrofits• Requirements other than energy modeling
Modeling for MA Stretch TEDI and Appendix G (8 hours)	Modelers	Detailed modeling requirements
Compliance documentation for MA Stretch TEDI and Appendix G (2 hours)	Code Officials & Modelers	<ul style="list-style-type: none">• Reporting templates• Other materials that must be submitted



2023 Massachusetts Stretch Energy Code Compliance Options Overview

Overview of MA Stretch 2023 (C401.2)

- Prescriptive Path: 2021 IECC with strengthening amendments
- Targeted Performance Path: Requires developing an energy model following the 2023 Stretch Code Targeted Performance Simulation Guidelines to demonstrate that project's heating and cooling Thermal Energy Demand Intensities (TEDIs) do not exceed the set limits. In addition, projects must meet selected requirements of the prescriptive path.
- Relative Performance Path: Requires energy modeling following 2019 ASHRAE 90.1 Appendix G and as described in 2023 Stretch Code ASHRAE Appendix G Simulation Guidelines using site energy metric with strengthening amendments. In addition, projects must meet selected requirements of the prescriptive path.
- Passive House: (Certification through either PHI or Phius), optional for any building type
- HERS Rating: Home Energy Rating System (HERS) index certification, optional for multi-family buildings

Overview of MA Stretch 2023

- Prescriptive Path: 2021 IECC with strengthening amendments
- Targeted Performance Path: Requires developing an energy model following the 2023 Stretch Code Targeted Performance Simulation Guidelines to demonstrate that project's heating and cooling Thermal Energy Demand Intensities (TEDIs) do not exceed the set limits. In addition, projects must meet selected requirements of the prescriptive path.
- Relative Performance Path: Requires energy modeling following 2019 ASHRAE 90.1 Appendix G and as described in 2023 Stretch Code ASHRAE Appendix G Simulation Guidelines using site energy metric with strengthening amendments. In addition, projects must meet selected requirements of the prescriptive path.
- Passive House: (Certification through either PHI or Phius), optional for any building type
- HERS Rating: Home Energy Rating System (HERS) index certification, optional for multi-family buildings

SCOPE OF
THIS TRAINING

Requirements Applicable to TEDI & Relative Performance

Modeler Qualification Requirements

Energy models must be created by persons qualified by education and training to perform such work.

The submittal package must include signatures of the licensed professional(s) as required for other compliance options.

In addition, the modeling documentation submitted to AHJ shall be signed by a professional meeting qualification requirements outlined in [Modeler Quals FINAL.pdf](#) (energycodes.gov) and summarized on the next slide.

Modeler Qualification Requirements



EXPERIENCE: The minimum of 3 years of full-time equivalent modeling experience OR successfully completion of at least 5 modeling projects; requirement is waived for professionals with ASHRAE BEMP certification.

TRAINING: A minimum of 8 hours of training completed in the last three years, including the following:

- Performance Based Compliance Documentation for ASHRAE 90.1 Section 11 and Appendix G (required)
- 2 hours minimum on ASHRAE 90.1 Section 11 or Appendix G
- Energy modeling training

CERTIFICATIONS: One of the following:

- ASHRAE Building Energy Modeling Professional (BEMP); High-Performance Building Design Professional (HBDP); Building Energy Assessment Professional (BEAP); Commissioning Professional (BCxP)
- Association of Energy Engineers Certifications Building Energy Simulation Analyst (BESA); Certified Energy Auditor (CEA) Certified Energy Manager (CEM); Existing Building Commissioning Professional (EBCP); Certified Building Commissioning Professional (CBCP)

EXAMPLE OF A THERMAL BRIDGE:

Brick ties which hold brick panel sections to the framing. Brick ties (A) which are used to connect the exterior brick to the building framing interrupt the exterior insulation (B)

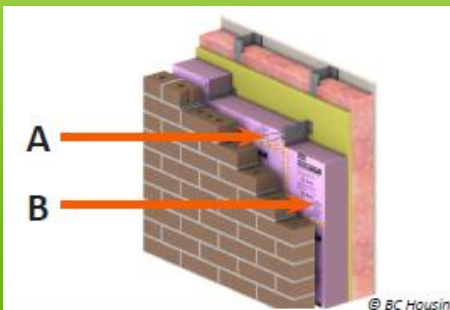

What is Thermal Bridging?

A thermal bridge is an interruption in an envelope assembly which reduces the overall thermal performance of the assembly. These interruptions allow unwanted heat transmission because they bypass the surrounding assembly insulation. They may impact energy efficiency, cause condensation within the building envelope, and lead to thermal discomfort.

The interruption causing a thermal bridge could be the result of a penetration in the assembly. Examples of this include supports for exterior wall cladding or rain screen, supports for brick cladding, brick shelves, balcony supports, and wall framing.

The interruption could also be caused by architectural transitions. Examples of this include building corners, vertical wall to roof transition (e.g. parapet), wall to window intersections, and intersection of interior floor to exterior vertical wall.

EXAMPLE OF A THERMAL BRIDGE:

Brick ties which hold brick panel sections to the framing. Brick ties (A) which are used to connect the exterior brick to the building framing interrupt the exterior insulation (B)

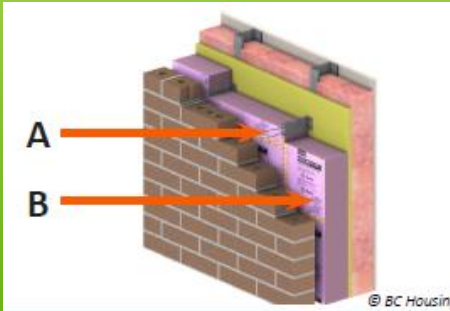

Types of Thermal Bridges

CLEAR FIELD: A thermal bridge that is uniformly distributed throughout an assembly such that accounting for the thermal bridge individually is impractical for whole-building calculations (e.g. steel framing).

LINEAR: A thermal bridge that is continuous in one direction of the exterior envelope (e.g., parapet).

POINT A thermal bridge that is discrete and countable on an individual basis for whole-building calculations (e.g. mounting brackets).

How Does a Project Account for Thermal Bridging?

mass.gov/info-details/stretch-energy-code-development-2022#final-guideline-

Web Tools Programs Equipment/Specs Admin Articles Maps-/Wea Tech & Software Recipes Development Technical Gu

Final Guideline

In September of 2023, DOER released a series of final Technical Guidance documents designed to inform and assist users in implementing the new Stretch and Specialized energy codes. Guidance documents include:

- [Final Stretch and Specialized Code Guidelines](#), including [Attachment A](#) (Envelope Performance and Thermal Bridge Derating), [Attachment B](#) (ASHRAE Appendix G Relative Performance Simulation Guidelines), [Attachment C](#) (Targeted Performance Simulation Guidelines), [Schedule and Loads Supplement](#), and [weather file](#).
- [Stretch Energy Code Study Support](#)
- [Models conforming to TEDI Requirements](#)

Exterior walls shall be modeled with the U-factors derated to account for thermal bridging using the derating methods described in Section C402.7. <https://www.mass.gov/info-details/stretch-energy-code-development-2022#final-guideline->

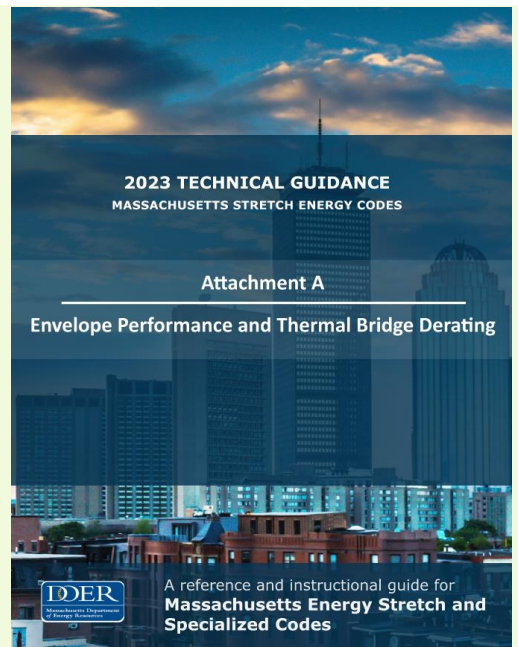

MA Stretch 2023 Mandatory Requirements

Code Requirements Other Than Envelope	Targeted Performance	Relative Performance
C406 Additional Efficiency Requirements Must implement efficiency measures to achieve at least 15 credits.	Yes	Yes, some measures may contribute to achieving the required modeled performance; others (e.g., heavy timber, fault detection and diagnostics, etc.).
C408 Maintenance Information and System Commissioning Unchanged from IECC; requires systems commissioning, functional testing and maintenance information.	Yes	Yes



Targeted Performance Path

Topics Covered

- Overview
- Mandatory requirements (quick reminder from 4 – hour TEDI and App G training)
- Approved simulation tools
- Climate and site data
- TEDI calculations and definition
- Unmet load hour limits
- Systems that should be included and excluded from the simulation
- Floor plan modeling requirements
- Building envelope properties
- Prescribed simulation inputs
- HVAC modeling requirements
- Special cases
- Extracting simulation results from approved tools to calculate TEDI
- Documentation requirements

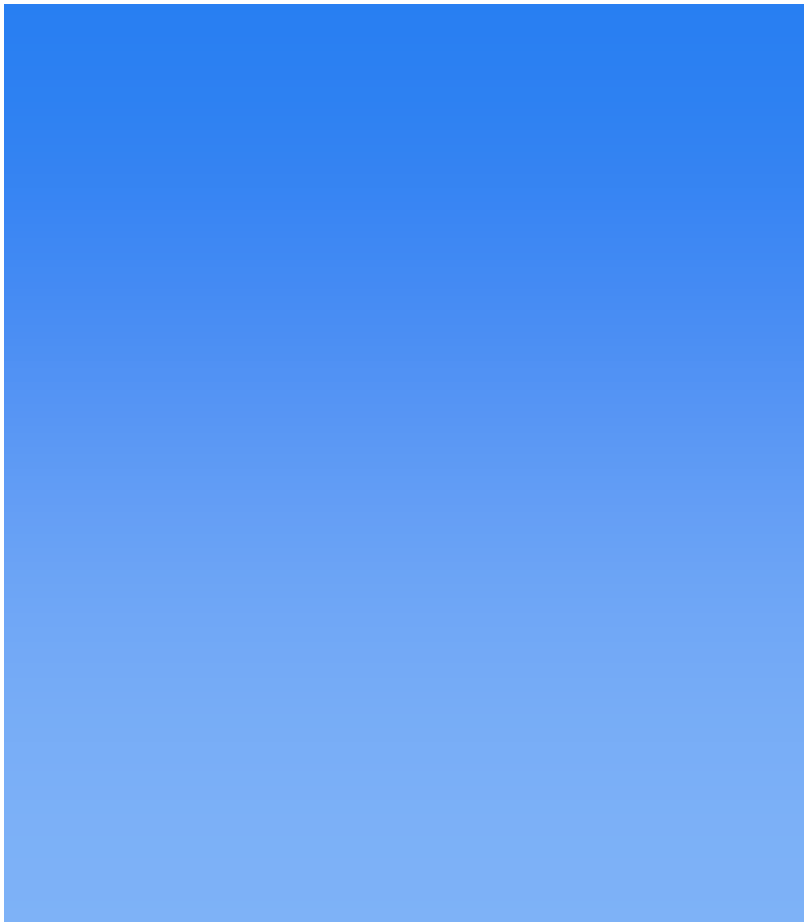

Overview



- **New compliance path**
- **Targets building envelope performance due to long useful life.**
- **Requires a whole building energy simulation**
- **Must follow modeling requirements in the [Targeted Performance Simulation Guidelines](#).**
- **Designs must demonstrate heating and cooling Thermal Energy Demand Intensities (TEDIs) no greater than the individual limits in Table C407.1.1.5 for the appropriate building type and size.**
- **Heating TEDIs are rounded to a single decimal point; cooling TEDI are rounded to the nearest whole number.**
- **Projects must also comply with additional requirements in [Section C401.2.1](#).**

Table C407.1.1.5 Thermal Energy Demand Intensity (TEDI Limits)

Use Type	Heating TEDI (kBtu/ft ² -yr)	Cooling TEDI (kBtu/ft ² -yr)
Office, fire station, library, police station, post office, town hall ≥ 125,000 ft ²	1.5	23
Office, fire station, library, police station, post office, town hall between 75,000 and 125,000 ft ²	4 – 0.00002* Area (ft ²)	18 + 0.00004* Area (ft ²)
Office, fire station, library, police station, post office, town hall ≤ 75,000 ft ²	2.5	21
K-12 School ≥ 125,000 ft ²	2.2	12
K-12 School between 75,000 and 125,000 ft ²	2.7 – 0.000004* Area (ft ²)	32 – 0.00016* Area (ft ²)
K-12 School ≤ 75,000 ft ²	2.4	20
Residential multifamily and dormitory ≥ 125,000 ft ²	2.8	22
Residential multifamily and dormitory between 75,000 and 125,000 ft ²	3.8 – 0.000008* Area (ft ²)	4.5 + 0.00014* Area (ft ²)
Residential multifamily and dormitory ≤ 75,000 ft ²	3.2	15
All other ≥ 125,000 ft ²	1.5	23
All other between 75,000 and 125,000 ft ²	4 – 0.00002* Area (ft ²)	18 + 0.00004* Area (ft ²)
All other ≤ 75,000 ft ²	2.5	21

MA Stretch Code 2023 Guidelines

mass.gov/info-details/stretch-energy-code-development-2022#final-guideline-

Web Tools Programs Equipment/Specs Admin Articles Maps+/Wea Tech & Software Recipes Development Technical Gu

Final Guideline

In September of 2023, DOER released a series of final Technical Guidance documents designed to inform and assist users in implementing the new Stretch and Specialized energy codes. Guidance documents include:

- [Final Stretch and Specialized Code Guidelines](#), including: [Attachment A](#) (Envelope Performance and Thermal Bridge Derating), [Attachment B](#) (ASHRAE Appendix G Relative Performance Simulation Guidelines), [Attachment C](#) (Targeted Performance Simulation Guidelines), [Schedule and Loads Supplement](#), and [weather file](#).
- [Stretch Energy Code Study Support](#)
- [Models conforming to TEDI Requirements](#)

[MA Stretch Code 2023 Guidelines](#)

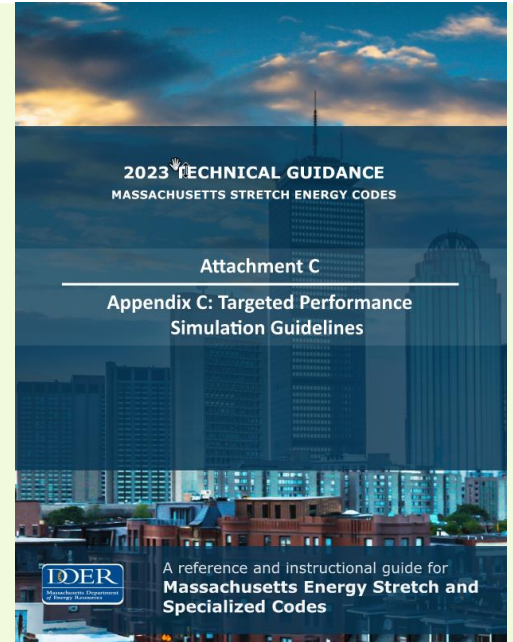

MA Stretch 2023 Envelope Mandatory Requirements

Code Requirement for Building Envelope	Targeted Performance
C401.3 Thermal envelope certification (Unchanged from IECC) Must post thermal envelope certificate with the key performance characteristics of the opaque envelope and fenestration and air leakage testing results.	Yes
C402.1.5 Component Performance Alternative <ul style="list-style-type: none"> • Allows performance trade-offs within vertical assemblies by prescribing limits on the area-weighted U-factor for above grade wall assemblies and whole assembly U-factors for vision glass glazed wall systems. The maximum allowed U-factors in either Section C402.1.5.1 or C402.1.5.2 depends on the percentage of the exterior wall taken up by glazed wall systems; • Fenestration shall meet the applicable SHGC requirements of Section C402.4.3. 	Yes, as alternative to compliance with the AGW U- factors in Tables C402.1.4 & vertical fenestration U- factors in Table C402.4 Required to comply with C402.
C402.2.8 Requirement for combustion fireplaces	Yes
C402.3 Rooftop solar readiness	Yes
C402.4.6 Fenestration Documentation Allowed methods for determining fenestration performance.	Yes
C402.5 Air Leakage Air barrier design and testing requirements; maximum allowed air leakage rates.	Yes
C402.7 Derating and Thermal Bridges Methodology that must be used to account for thermal bridging in exterior walls	Yes

Compliance with C402 is required!

(Reminder from 4-hour TEDI + App G training)

MA Stretch 2023 Mandatory Requirements

Code Requirements Other Than Envelope	Targeted Performance
C401.4.2 Full Space Heating Electrification	Yes, for high glazed wall system buildings (C402.1.5.2)
C403 Building Mechanical Systems	Yes
C404 Service Water Heating The minimum equipment efficiency and controls; piping insulation.	Yes
C405 Electric Power and Lighting Systems Interior and exterior lighting power and controls; electric metering; transformers; motors; vertical and horizontal transportation systems and equipment; voltage drop; automatic receptacle controls; energy monitoring; provisions for the electric vehicles ready parking spaces.	Yes

(Reminder from 4-hour TEDI + App G training)

Approved Simulation Tools



- **eQUEST version 3.65 or higher using the DOE2.3 engine**
Exception: DOE2.2 can be used for projects that do not include HVAC systems and designs that require workarounds in DOE2.2 but are explicitly supported in DOE2.3, such as variable refrigerant flow heat pumps and dedicated outdoor air systems.
- **Energy Plus version 9.3.0 or higher**
- **IES Virtual Environment version 2021.4.0.0 or higher**
- **When the approved simulation program does not model a specified design, material or device, an external calculation shall be used as approved by the AHJ. The documentation submitted in support of the external calculations shall include a narrative explaining the methods, theoretical or empirical information supporting its accuracy, and documentation required in ASHRAE 90.1 2019 Section G2.5 (a) – (e).**



Climate and Site Data

- Projects shall use [MAStretch2023 weather file](#) included in the Schedules and Loads Guidelines Supplement Package. Local weather file may be used when permitted by AHJ.
- Ground temperatures from the weather file or software defaults shall be used.
- The solar reflectance of the site ground surface shall equal 0.2.
- No holidays shall be modeled.
- Shading from adjacent structures, significant vegetation and topographical features shall be reflected in the simulation. All elements with height greater than their distance from a proposed building and whose width facing the proposed building is greater than one-third that of the proposed building shall be modeled.

Final Guideline

In September of 2023, DOER released a series of final Technical Guidance documents designed to inform and assist users in implementing the new Stretch and Specialized energy codes. Guidance documents include:

- [Final Stretch and Specialized Code Guidelines](#), including: [Attachment A](#) (Envelope Performance and Thermal Bridge Derating), [Attachment B](#) (ASHRAE Appendix G Relative Performance Simulation Guidelines), [Attachment C](#) (Targeted Performance Simulation Guidelines), [Schedule and Loads Supplement](#), and [weather file](#).
- [Stretch Energy Code Study Support](#)
- [Models conforming to TEDI Requirements](#)

<https://www.mass.gov/doc/2023-stretch-energy-code-weather-files/download>

Shading from Adjacent Structures Example

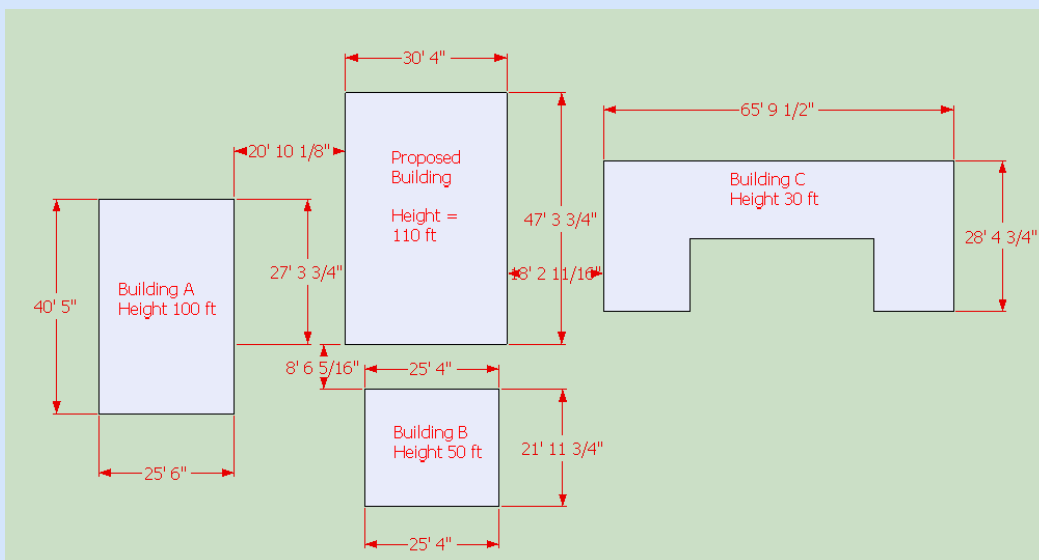

Question: Would it be required that the shading from Building A be captured in the simulation?

Shading from Adjacent Structures Example

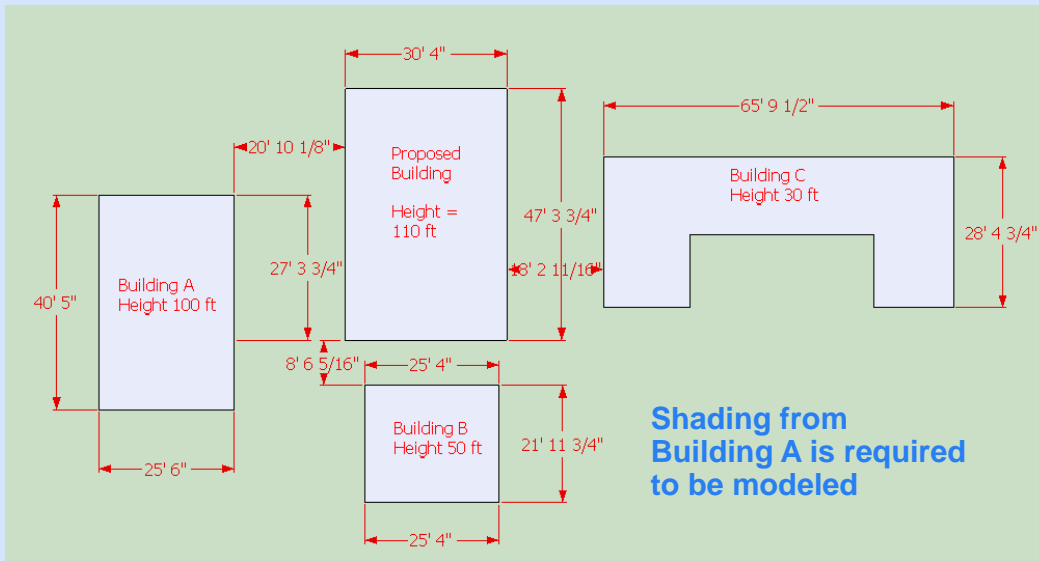

Answer: Building A

Criteria 1 check:

Distance from proposed building = 20' 10 1/8"

Height = 100 ft

Height is greater than the distance from the proposed building ✓

Criteria 2 check:

$\frac{1}{3}$ width of proposed = $47' 3 \frac{3}{4}'' * (\frac{1}{3}) = 15.77$ ft

Projected width of building A = 27' 3 3/4"

Projected width is greater than $\frac{1}{3}$ of the proposed building width ✓

Quiz #1

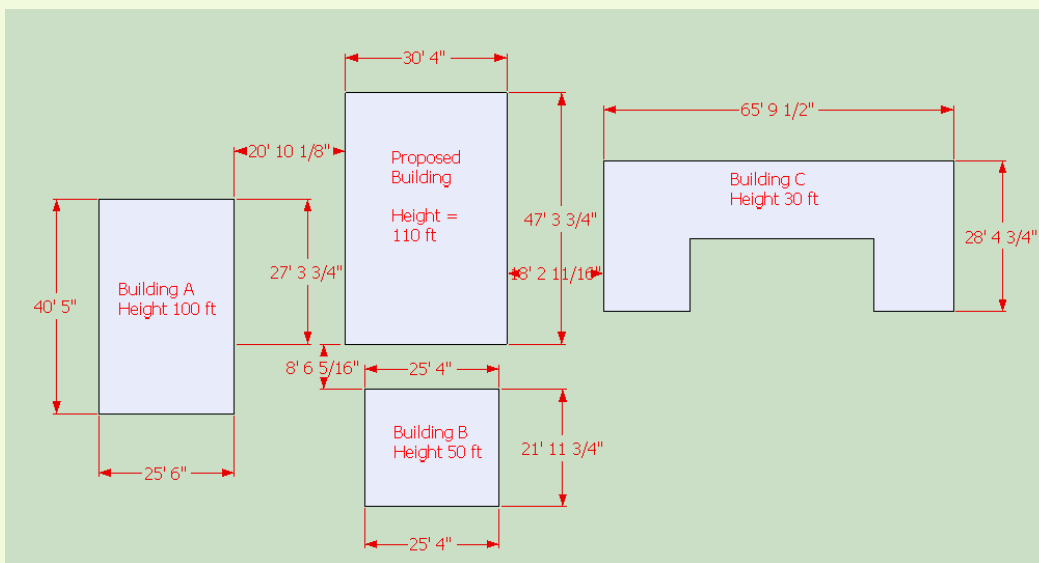

Question: Would shading from Building B need to be modeled?

- A. Yes
- B. No

Quiz #1

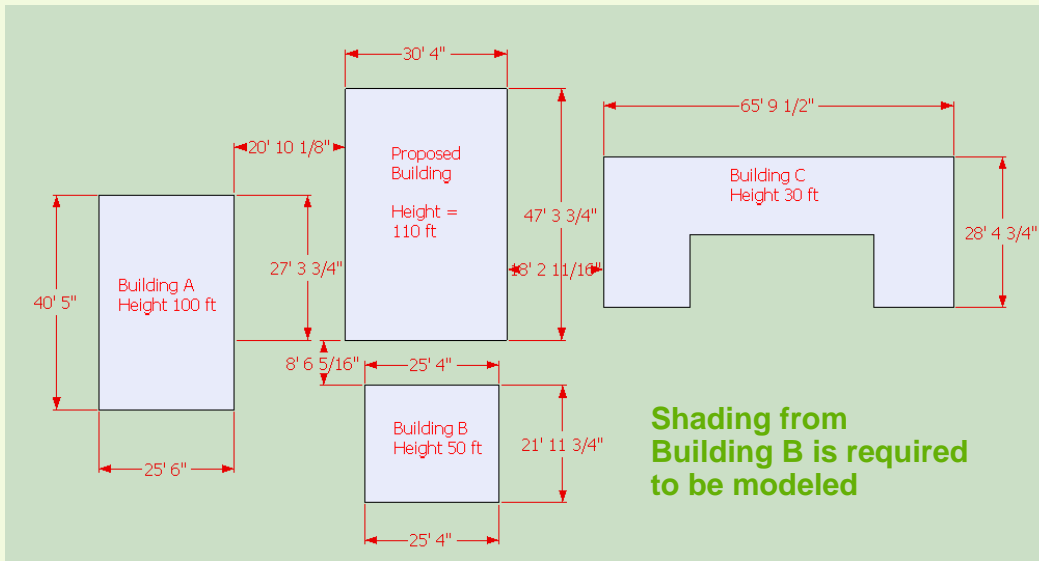

Answer: A Yes

Criteria 1 check:

Distance from proposed building = 8' 6 5/6"

Height = 50 ft

Height is greater than the distance from the proposed building ✓

Criteria 2 check:

1/3 width of proposed = 30' 4" * (1/3) = 10.11 feet

Projected width of building A = 25' 4"

Projected width is greater than 1/3 of the proposed building width ✓

TEDI Calculations: General Approach



- Emphasizes reducing heating and cooling loads by improvements to the building envelope and ventilation system design regardless of system type or efficiency.
- The heating TEDI is the annual heating energy delivered to the spaces and ventilation within the building to maintain heating thermostat setpoints normalized by the floor area.
- The cooling TEDI is the annual energy extracted from the spaces and ventilation to maintain cooling thermostat setpoint normalized by the floor area.

$$\text{Heating TEDI} \left[\frac{\text{kBtu}}{\text{ft}^2} \right] = \frac{\Sigma \text{ Space and Ventilation Heating Output [kBtu]}}{\text{Modeled Floor Area [ft}^2\text{]}}$$

$$\text{Cooling TEDI} \left[\frac{\text{kBtu}}{\text{ft}^2} \right] = \frac{\Sigma \text{ Space and Ventilation Cooling Output [kBtu]}}{\text{Modeled Floor Area [ft}^2\text{]}}$$

TEDI Calculations: Heating and Cooling Output



Σ Space and Ventilation Heating Output = the annual heating output of all systems in the building that maintain space temperature setpoints and heat ventilation air including the heating coils of the central air systems (e.g., make-up air units and air handling units) and terminal equipment (e.g., fan coils, heat pumps and unit heaters).

Σ Space and Ventilation Cooling Output = the annual cooling output of all HVAC systems that maintain space temperature setpoints and cool ventilation air, including but not limited to the cooling coils of the central air systems (e.g., make-up air units and air handling units) and terminal equipment (e.g., fan coils, heat pumps).

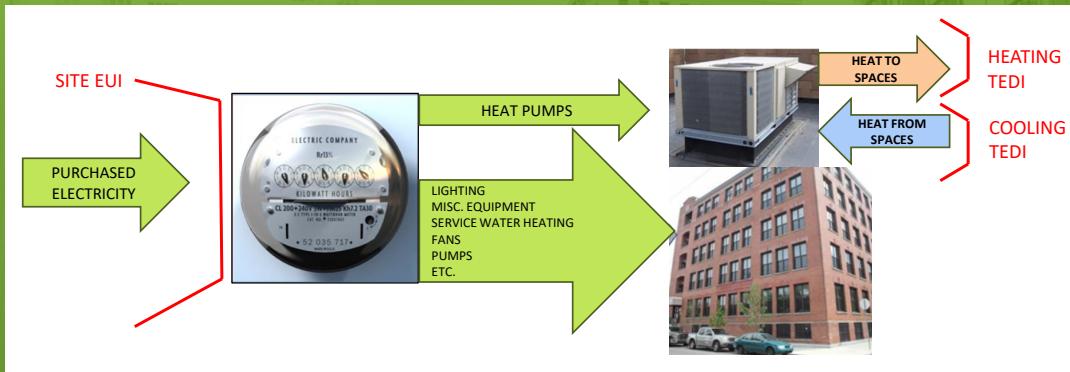

Simulation Guidelines Annex 1 includes steps for extracting the simulation outputs necessary to calculate cooling and heating TEDI from the simulation report generated by the approved energy modeling tools.

Quiz #2

Choose the correct statement.

- A. TEDI and site energy usage index (EUI) are identical concepts.
- B. Site energy usage index (EUI) represents the annual heating (or cooling) load on the HVAC systems (e.g., it represents the heating (or cooling) “need”).
- C. TEDI represents the annual amount of energy used to operate equipment that heats (or cools) the spaces and ventilation air.
- D. TEDI and site energy usage index (EUI) are distinct concepts.

Quiz #2

Choose the correct statement.

- A. TEDI and site energy usage index (EUI) are identical concepts.
- B. Site energy usage index (EUI) represents the annual heating (or cooling) load on the HVAC systems (e.g., it represents the heating (or cooling) “need”).
- C. TEDI represents the annual amount of energy used to operate equipment that heats (or cools) the spaces and ventilation air.
- D. TEDI and site energy usage index (EUI) are distinct concepts.

Quiz #3

True or False: Heating TEDI is the same as heating peak demand.

- A. True
- B. False

Quiz #3

True or False: Heating TEDI is the same as heating peak demand.

- A. True
- B. False

TEDI Calculations: Modeled Floor Area

Modeled floor area: the total enclosed floor area of the building, as reported by the simulation program, including conditioned and excluding unconditioned spaces.

Conditioned space (from IECC 2021): an area, room or space that is enclosed within the building thermal envelope that is directly or indirectly heated or cooled. Spaces are indirectly heated or cooled where they communicate through openings with conditioned spaces, where they are separated from conditioned spaces by uninsulated walls, floors, or ceilings, or where they contain uninsulated ducts, piping or other sources of heating or cooling.

Unconditioned space (from 90.1 2019): an enclosed space within a building that is not a conditioned space.

Modeled Floor Area: Special Cases and Rules

What if my project has a lot of heated only space?

If modeling as-designed HVAC systems per Sections 13.3 and 13.4 and heated only thermal zone floor area accounts for more than 10% of the modeled floor area, then the heated only floor area shall be subtracted from the Modeled Floor Area for the purposes of determining the Cooling TEDI.

Can unconditioned spaces be included in the energy model but be modeled as unconditioned and excluded from the Modeled Floor Area when determining TEDI?

Yes

How should atriums and other double heighted spaces be accounted for in the Modeled Floor Area?

The Modeled Floor Area must include only the floor area of the atrium and/or double heighted space. In other words, the footprint of the space is only counted once in the Modeled Floor Area.

Quiz #4

Which of the following would be included in the Modeled Floor Area?

- a. Parking garage thermally isolated from adjacent conditioned spaces (i.e., not enclosed within the building thermal envelope).
- b. Crawl space thermally isolated from adjacent conditioned spaces (i.e., not enclosed within the building thermal envelope).
- c. Storage room with no HVAC equipment serving it directly and with no insulation between it and adjacent directly conditioned spaces.
- d. Storage room with no HVAC equipment serving it directly and with insulation isolating it from adjacent directly conditioned spaces.

Quiz #4

Which of the following would be included in the Modeled Floor Area?

- a. Parking garage thermally isolated from adjacent conditioned spaces (i.e., not enclosed within the building thermal envelope).
- b. Crawl space thermally isolated from adjacent conditioned spaces (i.e., not enclosed within the building thermal envelope).
- c. Storage room with no HVAC equipment serving it directly and with no insulation between it and adjacent directly conditioned spaces.
- d. Storage room with no HVAC equipment serving it directly and with insulation isolating it from adjacent directly conditioned spaces.

Quiz #5

Assuming all spaces within the building shown on the slide are conditioned what would be the Modeled Floor Area of the building?

- A. 20,400 sf
- B. 10,200 sf
- C. 13,800 sf

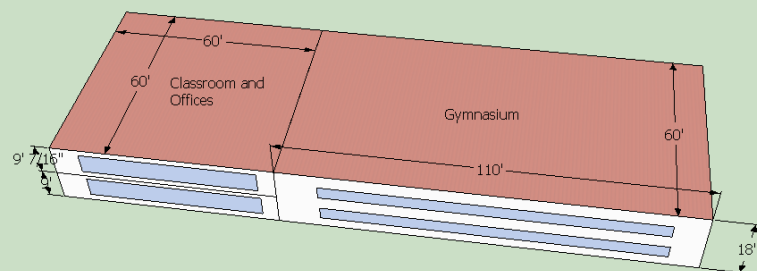

Quiz #5

Assuming all spaces within the building shown on the slide are conditioned what would be the Modeled Floor Area of the building?

Answer: C

$(60' \times 60' \times 2 \text{ floors}) + (110' \times 60' \times 1 \text{ floor}) = 13,800 \text{ ft}^2$

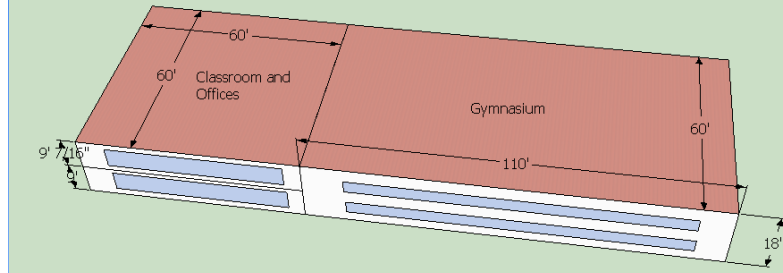

Unmet Load Hour Limits



Unmet load hours shall not exceed 300 (of the 8760 hours simulated).

Unmet load hours exceeding these limits shall be permitted to be accepted by the AHJ, provided that sufficient justification is given indicating that the accuracy of the simulation is not compromised by these unmet loads.

When might a reviewer consider accepting unmet load hours greater than the allowed limited?

- Small margin
- Low applicable floor area
- Small rise or drop in temperature outside of acceptable range

Unmet load hour: an hour in which one or more zones is outside of the thermostat set point plus or minus one half of the temperature control throttling range. Any hour with one or more zones with an unmet cooling load or unmet heating load is defined as an unmet load hour.

Systems Excluded from the Simulation

Systems that do not interact with heating and cooling loads of the building or that are not permanent must be excluded from the simulations.

- Exterior lighting system power and controls
- Heating loads unrelated to maintaining indoor air related occupant comfort such as swimming pool water heaters, outdoor comfort heating (e.g., patio heaters and exterior fireplaces), gas-fired appliances (stoves and dryers), heat tracing.
- Renewable energy systems including but not limited to PV and solar thermal hot water collectors
- Other electricity generation systems such as combined heat and power.
- Service water heating systems.

Quiz #6

Which of the following systems/components should be included in the TEDI model?

- A. Swimming pool heater
- B. Heat trace on hot water piping running through a parking garage
- C. Perimeter electric resistance supplemental heating when modeling as-designed systems
- D. Exterior lighting

Quiz #6

Which of the following systems/components should be included in the TEDI model?

- A. Swimming pool heater
- B. Heat trace on hot water piping running through a parking garage
- C. Perimeter electric resistance supplemental heating when modeling as-designed systems
- D. Exterior lighting

Systems That Must Be Modeled as Specified

- a. Opaque envelope insulation accounting for thermal bridges and thermal mass effects
- b. Fenestration area and orientation
- c. Thermal and solar properties of windows and skylights
- d. Shape of exterior envelope
- e. Envelope air leakage
- f. Building orientation
- g. Fixed exterior shading (e.g., fenestration set back in envelope plane, side fins, and overhangs) and site shading (e.g., from surrounding buildings).
- h. Mechanical ventilation rate when it exceeds the prescribed value determined in 13.4.1.
- i. Exhaust air energy recovery effectiveness.

Prescribed Simulation Inputs

Prescribed inputs correspond to the design elements and operating conditions that are not meant to impact compliance. Examples of prescribed inputs:

- a. Weather file (unless alternative is approved by AHJ)
- b. Minimum mechanical ventilation rates, except when the specified ventilation rate exceeds the prescribed value determined in 13.4.1
- c. Interior lighting system power and controls
- d. Miscellaneous plug and process loads and schedules
- e. Operating and occupancy schedules such as building operating hours, lighting runtime, thermostat setpoints, etc.

HVAC Modeling Requirements



HVAC Option 1: Model default HVAC system prescribed in the TEDI Technical Guidelines

- Required for buildings and areas within the building for which HVAC systems are not designed and are not shown on the construction documents.
- Allowed for all other buildings.

HVAC Option 2: Model as-designed HVAC Systems and Controls

- Allowed for projects where an HVAC system has been designed and submitted with design documents
- The modeled HVAC systems must be consistent with design documents with the following exceptions (this also applies to Option 1):
 - Airflows and heating and cooling capacities must be auto-sized using a prescribed methodology.
 - Modeled ventilation rates must be determined as follows:
 - As specified if the specified rate (1) exceeds the prescribed ventilation rate AND (2) exceeds the minimum code requirements by more than 135%,
 - Prescribed ventilation rate for the building use type in all other cases

Note: Minimum required outdoor air and specified ventilation rates shall be documented as described in Section C103.2 #16.

Floor Plan Modeling: Thermal Blocks

Required for projects modeling as-designed HVAC systems (Option 1):

Thermal blocks shall be modeled as prescribed in 90.1 2019 Appendix G Table G3.1, Proposed Building Performance column Row 9 for multifamily buildings and Row 7 for all other occupancy types.

Exception (Option 2): Projects that are modeled with the default HVAC system following Section 13.2 are permitted to be modeled with the default thermal blocks as prescribed in Sections 8.2 and 8.3

Floor Plan Modeling

Thermal Blocks: 90.1 2019 Appendix G Table G3.1, Proposed Building Performance Column Rules, Rows 7 and 9



HVAC zones must be modeled individually or combined into a single thermal block if all of the following conditions are met:

- The space use classification is the same throughout the thermal block
- All HVAC zones in the thermal block that are adjacent to glazed exterior walls face the same orientation or their orientations vary by less than 45 degrees.
- All of the zones are served by the same HVAC system or by the same kind of HVAC system.
- Separate thermal blocks shall be modeled for zones having floors that are in contact with the ground or exposed to ambient conditions and for zones having exterior ceiling or roof assemblies from zones that do not share these features.

Special rules for residential spaces:

- At least one thermal block per dwelling unit, except units facing the same orientations may be combined into one thermal block.
- Corner units and units with roof or floor loads may only be combined with similar units.

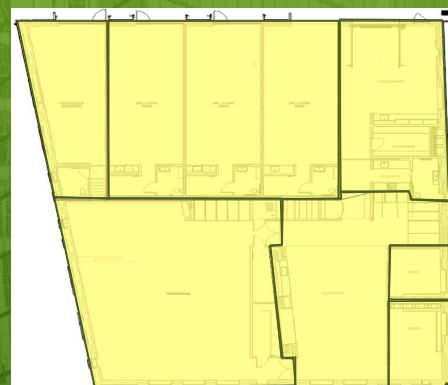
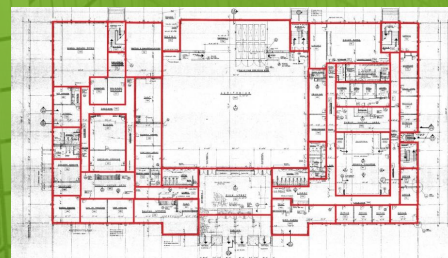

Quiz #7

A project is a one-story town hall served by six single-zone roof-top units (RTU 1 – RTU 6).

How many thermal blocks should be modeled?

- A. Twenty-eight, one for each space
- B. Six, with all spaces served by each single-zone RTU modeled as one thermal block
- C. Three, including one for auditorium (RTU-1), one for all spaces served by RTU-4, and another one for all offices served by RTUs 2,3,5 &6 (they can be aggregated since each zone is the same occupancy type)
- D. One, because the entire building is a commercial occupancy
- E. Other

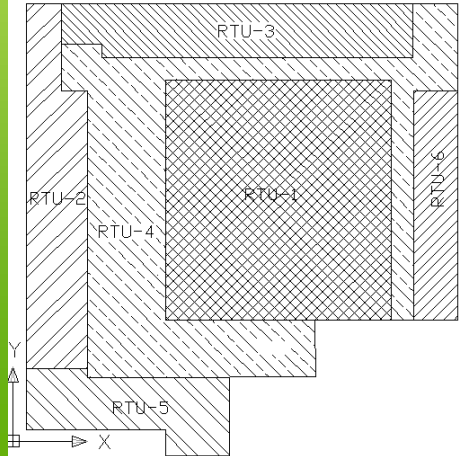

Quiz #7

A project is a one-story town hall served by six single-zone roof-top units (RTU 1 – RTU 6).

How many thermal blocks should be modeled?

- A. Twenty-eight, one for each space
- B. Six, with all spaces served by each single-zone RTU modeled as one thermal block**
- C. Three, including one for auditorium (RTU-1), one for all spaces served by RTU-4, and another one for all offices served by RTUs 2,3,5 &6 (they can be aggregated since each zone is the same occupancy type)
- D. One, because the entire building is a commercial occupancy
- E. Other

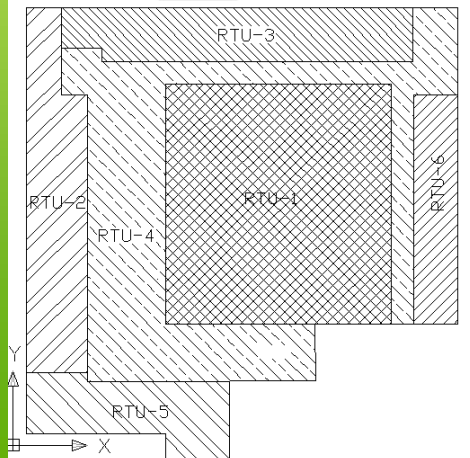

Quiz #8

A ten-story multifamily building has the same floor plan on each floor. Stairwells and corridor each have thermostatically controlled electric resistance baseboards. Trash room does not have thermostat but has exhaust fan pulling air from corridor. Elevator shaft is NOT part of the building thermal envelope.

How many thermal blocks must be explicitly modeled on each multifamily floor?

- One - all spaces on each floor may be aggregated into one thermal block
- Three - one thermal block includes corridor and trash room, another includes stairwells, and third with all apartments
- Six - one thermal block includes corridor and trash room, another includes stairwells, plus three thermal blocks each including all apartments facing the same exposure
- Nine - one thermal block includes corridor and trash room, another includes stairwells, plus 7 thermal blocks for apartments because corner apartments cannot be aggregated into the same thermal block with non-corner apartments
- Other

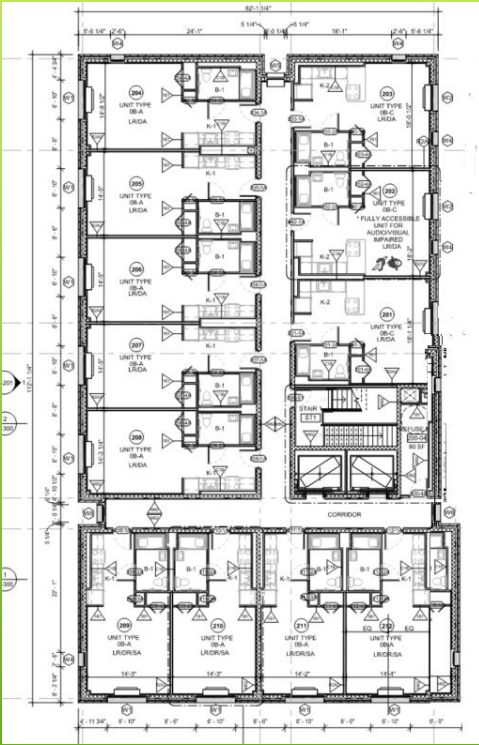

Quiz #8

A ten-story multifamily building has the same floor plan on each floor. Stairwells and corridor each have thermostatically controlled electric resistance baseboards. Trash room does not have thermostat but has exhaust fan pulling air from corridor. Elevator shaft is NOT part of the building thermal envelope.

How many thermal blocks must be explicitly modeled on each multifamily floor?

- One - all spaces on each floor may be aggregated into one thermal block
- Three - one thermal block includes corridor and trash room, another includes stairwells, and third with all apartments
- Six - one thermal block includes corridor and trash room, another includes stairwells, plus three thermal blocks each including all apartments facing the same exposure
- Nine - one thermal block includes corridor and trash room, another includes stairwells, plus 7 thermal blocks for apartments because corner apartments cannot be aggregated into the same thermal block with non-corner apartments
- Other

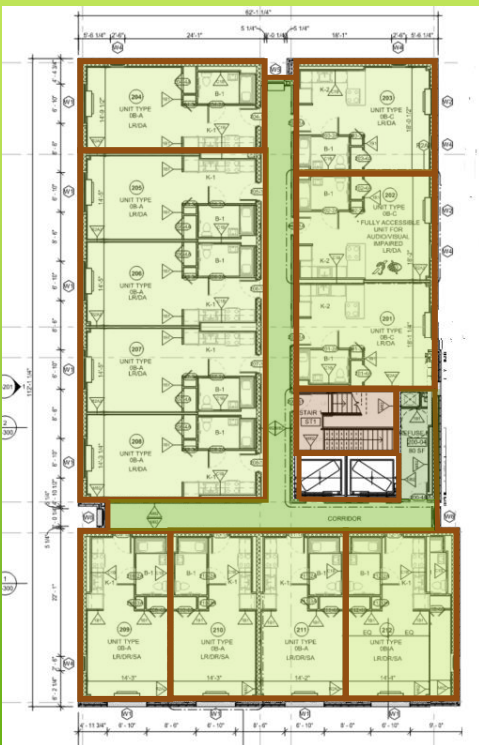

Floor Plan Modeling Thermal Blocks: Exception for Projects Modeling Default HVAC Systems

Required for projects modeling as-designed HVAC systems (Option 1):

Thermal blocks shall be modeled as prescribed in 90.1 2019 Appendix G Table G3.1, Proposed Building Performance column Row 9 for multifamily buildings and Row 7 for all other occupancy types.

Exception (Option 2): Projects that are modeled with the default HVAC system following Section 13.2 are permitted to be modeled with the default thermal blocks as prescribed in Sections 8.2 and 8.3

Floor Plan Modeling Thermal Blocks: Exception for Projects Modeling Default HVAC Systems

Floor Plan Option 2: Projects modeled with default HVAC system may use default perimeter/core thermal blocks based on building use type.

The building geometry simplifications are similar to those appropriate for early design modeling cycles, such as the Load Reduction cycle, described in the ASHRAE Standard 209 Computer Simulation Aided Design. They allow evaluating compliance with Section C407.1 early in the design process before the building programming and HVAC zoning schemes are finalized.

Default Thermal Blocks

Building Use Type	Types of Thermal Blocks
Residential	<ul style="list-style-type: none"> Residential areas (dwelling units and dormitory rooms; perimeter/core not required) Supporting areas (corridors, stairs, trash rooms, lobbies, mechanical rooms; perimeter/core not required) Nonresidential areas (lounges, laundry, leasing office, fitness rooms, common bathrooms, community rooms, etc.)
K-12 Schools	<ul style="list-style-type: none"> Cafeteria; Gymnasium; Auditorium (perimeter/core not required) School (classrooms, corridors, restrooms, offices)
Offices, fire stations, libraries, police stations, post offices, town halls	<ul style="list-style-type: none"> Office thermal blocks representing spaces typical for office buildings

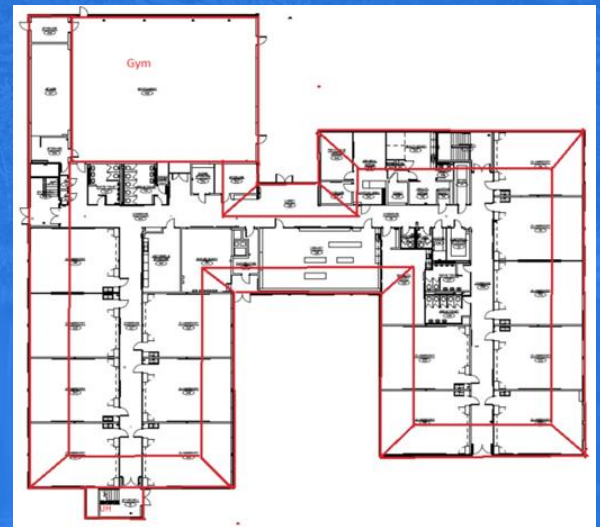

Other Rules for Default Thermal Blocks

A separate thermal block shall be provided for each space adjacent to glazed exterior walls by orientation (except for orientations that differ by less than 45 degrees). Each thermal block shall include all floor area that is 15 feet or less from a glazed perimeter exterior wall.

Separate thermal blocks shall be modeled for zones having floors that are in contact with the ground or exposed to ambient conditions and for zones having exterior ceiling or roof assemblies from zones that do not share these features.

Zones served by mechanical systems with exhaust air energy recovery shall not be aggregated into the same thermal block with zones served by mechanical systems that do not have exhaust air energy recovery.

Office Example (all zones are served by HVAC system with exhaust air energy recovery)

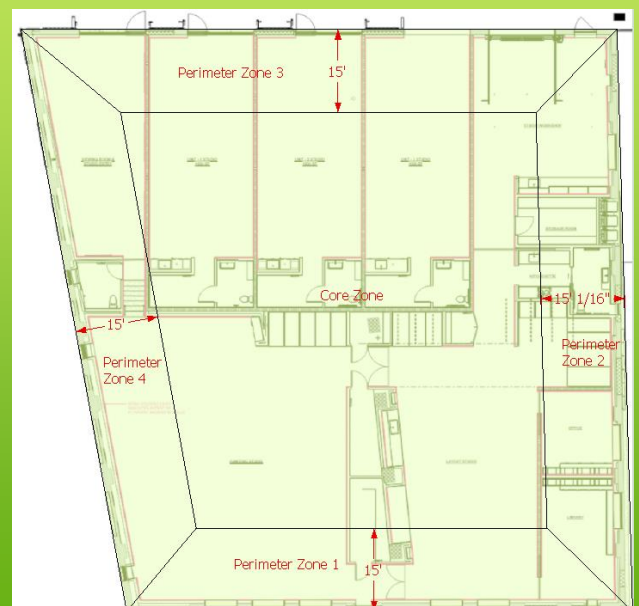

Perimeter Core Zoning

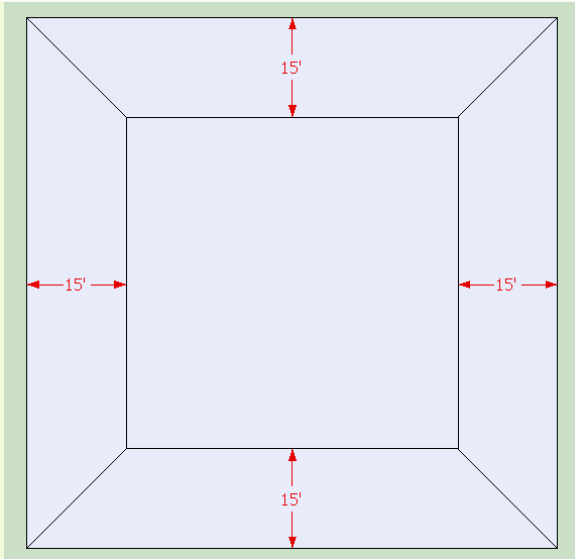

Simple graphic to illustrate concept. Assumes that each orientation includes fenestration.

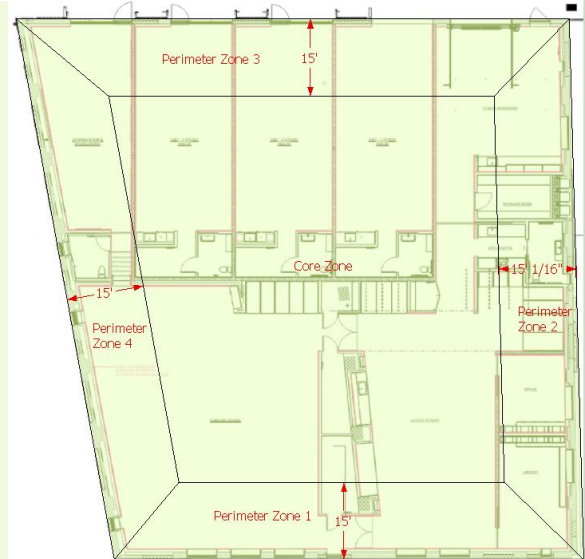

Office Example (all zones are served by HVAC system with exhaust air energy recovery)

Quiz #9

True or False: Projects modeling default HVAC systems are also required to use the default approach in Sections 8.2 and 8.3 for establishing thermal blocks (i.e., perimeter/core zoning)?

- A. True
- B. False

Quiz #9

True or False: Projects modeling default HVAC systems are also required to use the default approach in Sections 8.2 and 8.3 for establishing thermal blocks (i.e., perimeter/core zoning)?

- A. True
- B. False

Building Envelope Shape and Areas Required Alignment



- The total modeled floor area of conditioned spaces shall be within 5% of the gross floor area shown on the architectural drawings unless justification is provided to AHJ.
- The modeled floor area of residential and nonresidential thermal blocks in residential buildings and cafeteria, gymnasium and auditorium thermal blocks in K-12 schools shall be within 5% of the actual design shown on construction documents.
- The modeled exterior envelope geometry must be consistent with construction documents, including proper accounting of fenestration and opaque building envelope types and areas.
- Each modeled thermal block must reflect the total area, type and orientation of opaque surfaces (i.e., above and below-grade exterior walls, roof, above and below grade floors) and fenestration associated with the spaces included in the block.

Common reasons for the deviation between the *modeled floor area* and the floor area reported on construction documents include differences in accounting for area taken by interior partitions, mechanical chutes and stairwells and thickness of exterior walls.

Building Envelope Properties

- All components of the building envelope must be modeled as shown on architectural drawings
- Simulation must account for thermal mass of the exterior surfaces.
- Exterior walls must be modeled with the U-factors derated to account for thermal bridging as required in Section C402.7.
- Fenestration must be modeled based on NFRC rating or using default (inefficient) properties (90.1 Table A8.1 for skylights & Table A8.2 for vertical fenestration).
- Manual shading devices, such as blinds or shades, may only be modeled in the residential spaces.
- Automatically controlled shades or blinds must not be modeled.
- Permanent shading such as from fins, overhangs, light shelves and fenestration setbacks must be modeled.
- Automatically or manually controlled dynamic glazing may be modeled.

Table A8.1-1 Assembly U-Factors for Unlabeled Skylights

Product Type		Sloped Installation						
		Unlabeled Skylight with Curb (Includes Glass/Plastic, Flat/Domed, Fixed/Operable)				Unlabeled Skylight without Curb (Includes Glass/Plastic, Flat/Domed, Fixed/Operable)		
Frame Type		Aluminum without Thermal Break	Aluminum with Thermal Break	Reinforced Vinyl/ Aluminum Clad Wood	Wood/ Vinyl	Aluminum without Thermal Break	Aluminum with Thermal Break	Structural Glazing
ID	Glazing Type							
Single Glazing								
1	1/8 in. glass	1.98	1.89	1.75	1.47	1.36	1.25	1.25
2	1/4 in. acrylic/ polycarb	1.82	1.73	1.60	1.31	1.21	1.10	1.10
3	1/8 in. acrylic/ polycarb	1.90	1.81	1.68	1.39	1.29	1.18	1.18
Double Glazing								
4	1/4 in. acrylic/ polycarb	1.31	1.11	1.05	0.84	0.82	0.70	0.66

Quiz #10

True or False: Projects can include permanent shading such as overhangs in TEDI models?

- A. True
- B. False

Quiz #10

True or False: Projects can include permanent shading such as overhangs in TEDI models?

- A. True
- B. False

Infiltration (i.e. Air Leakage)

- The modeled air leakage rate of the building envelope shall be based on air leakage testing completed following Section C402.5.2.
- Since model will ultimately be updated to reflect the test results, avoid using overly optimistic air leakage assumptions to ensure that TEDI compliance is not jeopardized.

For example, 0.35 cfm/ft² at 75Pa, the maximum allowed in Section C402.5.2, may be used as an early air leakage estimate.

Infiltration Modeling

- The air leakage rate of the building envelope shall be converted to appropriate units for the simulation program using one of the methods in 90.1 90.1 Section G3.1.1.4.
- The infiltration flow shall be assigned to the thermal blocks in proportion to the area of surfaces adjacent to exterior.
- Infiltration schedule shall be as specified in the Schedules and Loads Guidelines Supplement for the appropriate thermal block type.

Modeling Infiltration Example

- A. Gross floor area: 12,918 ft²
- B. Gross roof area: 12,918 ft²
- C. Slab-on-grade floor area: 12,918 ft²
- D. Total gross above grade exterior wall area: 6,545 ft²
- E. Total volume: 161,058 ft³

A 12,918 ft² office building completed air leakage testing, and the rate measured following ASTM E3158 test is 0.30 cfm/ft² at a pressure differential of 0.3 inch water gauge (75 Pa). How should air leakage be modeled for each thermal block given that the infiltration flow is required to be assigned to the thermal blocks in proportion to the area of surfaces adjacent to exterior?

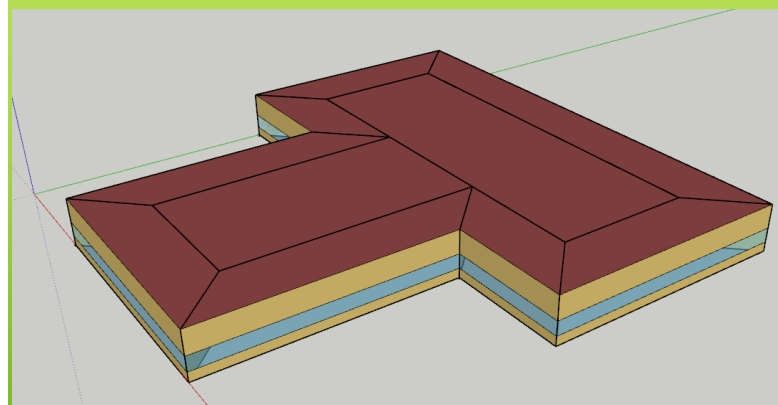

Modeling Infiltration (Mistake in 90.1)



G3.1.1.4 Modeling Building Envelope Infiltration

The air leakage rate of the *building envelope* (I_{75Pa}) at a pressure differential of 0.3 in. of water shall be converted to appropriate units for the *simulation program* using one of the following formulas:

For methods describing air leakage as a function of *floor area*,

$$I_{FLR} = 0.112 \times I_{75Pa} \times S/A_{FLR}$$

For methods describing air leakage as a function of the area of *above-grade walls* that separate *conditioned spaces* and *semiheated spaces* from the exterior,

$$I_{AGW} = 0.112 \times I_{75Pa} \times S/A_{AGW}$$

When using the measured air leakage rate of the *building envelope* at a pressure differential of 0.3 in. of water for the *proposed design*, the air leakage rate shall be calculated as follows:

$$I_{75Pa} = Q/S$$

where

I_{75Pa} = air leakage rate of the *building envelope* (cfm/ft²) at a fixed *building* pressure differential of 0.3 in. of water, or 1.57 psf

Q = volume of air in cfm flowing through the *building envelope* when subjected to a pressure differential of 0.3 in. of water, or 1.57 psf, in accordance with ASTM E 779

S = total area of the *building envelope* (ft²), including the lowest floor, any below-grade walls or above-grade walls, and roof (including vertical fenestration and skylights)

I_{FLR} = adjusted air leakage rate of the *building envelope* (cfm/ft²) at a reference wind speed of 10 mph and relative to the *gross floor area*

A_{FLR} = *gross floor area*, ft²

I_{AGW} = adjusted air leakage rate of the *building envelope* (cfm/ft²) at a reference wind speed of 10 mph and relative to the area of the *above-grade walls* of the *building envelope*

A_{AGW} = total area of *above-grade walls* of the *building envelope*, ft²

ERRATA SHEET FOR ANSI/ASHRAE/IES STANDARD 90.1-2019 (I-P Edition) Energy Standard for Buildings Except Low-Rise Residential Buildings

February 15, 2024

G3.1.1.4 Modeling Building Envelope Infiltration. Revise Section G3.1.1.4 as follows. (Note: Additions are shown in underline and deletions are shown in ~~strickthrough~~.)

S = total area of the *building envelope* (ft²), including the lowest floor, any below-grade walls or above-grade walls, and roof (including vertical fenestration and skylights)

Definition of floor in 90.1 2019

floor: that lower portion of the *building envelope*, including *opaque area* and *fenestration*, that has conditioned or *semiheated space* above and is horizontal or tilted at an angle of less than 60 degrees from horizontal but excluding slab-on-grade floors. For the purposes of determining *building envelope* requirements, the classifications are defined as follows:

mass floor: a *floor* with a *heat capacity* that exceeds (a) 7 Btu/ft²·°F or (b) 5 Btu/ft²·°F, provided that the *floor* has a material unit mass not greater than 120 lb/ft³.

steel-joint floor: a *floor* that (a) is not a *mass floor* and (b) has *steel joist* members supported by structural members.

wood-framed and other floors: all other *floor* types, including wood-joint *floors*.

The TEDI limits and guidelines were developed with this mistake (i.e., excluding slab on grade floors) so it is important to also exclude them when calculating “S” for your projects (per communication with MA DOER it is also okay to exclude below grade and exposed floor area as well).

Modeling Infiltration Example

Whole building level calculations:

A. Gross floor area: 12,918 ft²

B. Gross roof area: 12,918 ft²

C. Slab-on-grade floor area: 12,918 ft²

D. Total gross above grade exterior wall area 6,545 ft²

E. Total volume: 161,058 ft³

$$I_{75Pa} = 0.3 \text{ CFM/ft}^2 \text{ (test result)}$$

$$I = 0.3 \text{ CFM/ft}^2 * 0.112 = 0.0336 \text{ CFM/ft}^2$$

$$S = 12,918 \text{ ft}^2 + 6,545 \text{ ft}^2 = 19,463 \text{ ft}^2$$

$$Q_{75Pa} = 0.3 \text{ CFM/ft}^2 * 19,463 \text{ ft}^2 = 5,838.9 \text{ CFM}$$

$$Q = 0.0336 \text{ CFM/ft}^2 * 19,463 \text{ ft}^2 = 654 \text{ CFM}$$

$$IFLR = 654 \text{ CFM}/12,918 \text{ ft}^2 = 0.051 \text{ CFM/ft}^2$$

$$IAGW = 654 \text{ CFM}/6,545 \text{ ft}^2 = 0.099 \text{ CFM/ft}^2$$

$$ACH = (654 \text{ CFM} * 60)/161,058 \text{ ft}^3 = 0.2436$$

G3.1.1.4 Modeling Building Envelope Infiltration

The air leakage rate of the *building envelope* (I_{75Pa}) at a pressure differential of 0.3 in. of water shall be converted to appropriate units for the *simulation program* using one of the following formulas:

For methods describing air leakage as a function of *floor area*,

$$I_{FLR} = 0.112 \times I_{75Pa} \times S/A_{FLR}$$

For methods describing air leakage as a function of the area of *above-grade walls* that separate *conditioned spaces* and *semiheated spaces* from the exterior,

$$I_{AGW} = 0.112 \times I_{75Pa} \times S/A_{AGW}$$

When using the measured air leakage rate of the *building envelope* at a pressure differential of 0.3 in. of water for the *proposed design*, the air leakage rate shall be calculated as follows:

$$I_{75Pa} = Q/S$$

where

I_{75Pa} = air leakage rate of the *building envelope* (cfm/ft²) at a fixed *building* pressure differential of 0.3 in. of water, or 1.57 psf

Q = volume of air in cfm flowing through the *building envelope* when subjected to a pressure differential of 0.3 in. of water, or 1.57 psf, in accordance with ASTM E 779

S = total area of the *building envelope* (ft²), including the lowest *floor*, any *below-grade walls* or *above-grade walls*, and *roof* (including *vertical fenestration* and *skylights*)

I_{FLR} = adjusted air leakage rate of the *building envelope* (cfm/ft²) at a reference wind speed of 10 mph and relative to the *gross floor area*

A_{FLR} = *gross floor area*, ft²

I_{AGW} = adjusted air leakage rate of the *building envelope* (cfm/ft²) at a reference wind speed of 10 mph and relative to the area of the *above-grade walls* of the *building envelope*

A_{AGW} = total area of *above-grade walls* of the *building envelope*, ft²

Modeling Infiltration Example



Calculations for modeling air leakage for each thermal block (required)

$I_{75Pa} = 0.3 \text{ CFM/ft}^2$ (test result)

Variable ID:	a1	a2	b	c	d	e = b+c	f	g=f*0.112	h=f*e	j=g*e	k=j/a1	m=j/b	n=(j*60)/a2
Thermal Block	Floor Area [ft ²]	Volume [ft ³]	Ext Wall Area [ft ²]	Roof Area [ft ²]	SOG Area [ft ²]	S [ft ²]	I_{75Pa} [CFM/ft ²]	I [CFM/ft ²]	Q_{75Pa} [CFM]	Q [CFM/ft ²]	I_{FLR} [CFM/ft ²]	I_{AGW} [CFM/ft ²]	ACH
STORY 1 WEST UPPER PERIMETER SPACE	759	9,464	818	759	759	1,577	0.30	0.034	473	53	0.069814	0.064775	0.34
STORY 1 SOUTH CORE SPACE	2,338	29,152	0	2,338	2,338	2,338	0.30	0.034	701	79	0.033600	0.000000	0.16
STORY 1 SOUTH UPPER LEFT PERIMETER SPACE	492	6,134	409	492	492	901	0.30	0.034	270	30	0.061539	0.074008	0.30
STORY 1 WEST LOWER PERIMETER SPACE	984	12,267	818	984	984	1,802	0.30	0.034	541	61	0.061539	0.074008	0.30
STORY 1 NORTH PERIMETER SPACE	1,743	21,732	1,636	1,743	1,743	3,379	0.30	0.034	1,014	114	0.065142	0.069392	0.31
STORY 1 NORTH CORE SPACE	3,608	44,981	0	3,608	3,608	3,608	0.30	0.034	1,082	121	0.033600	0.000000	0.16
STORY 1 EAST UPPER PERIMETER SPACE	759	9,464	818	759	759	1,577	0.30	0.034	473	53	0.069814	0.064775	0.34
STORY 1 EAST LOWER PERIMETER SPACE	984	12,267	818	984	984	1,802	0.30	0.034	541	61	0.061539	0.074008	0.30
STORY 1 SOUTH UPPER LEFT PERIMETER SPACE 1	492	6,134	409	492	492	901	0.30	0.034	270	30	0.061539	0.074008	0.30
STORY 1 SOUTH LOWER PERIMETER SPACE	759	9,464	818	759	759	1,577	0.30	0.034	473	53	0.069814	0.064775	0.34
Total	12,918	161,058	6,545	12,918	12,918	19,463	-	-	5,839	654	-	-	-

Modeling Infiltration Example

Model inputs for eQuest:

Thermal Block	ACH
STORY 1 WEST UPPER PERIMETER SPACE	0.34
STORY 1 SOUTH CORE SPACE	0.16
STORY 1 SOUTH UPPER LEFT PERIMETER SPACE	0.30
STORY 1 WEST LOWER PERIMETER SPACE	0.30
STORY 1 NORTH PERIMETER SPACE	0.31
STORY 1 NORTH CORE SPACE	0.16
STORY 1 EAST UPPER PERIMETER SPACE	0.34
STORY 1 EAST LOWER PERIMETER SPACE	0.30
STORY 1 SOUTH UPPER LEFT PERIMETER SPACE 1	0.30
STORY 1 SOUTH LOWER PERIMETER SPACE	0.34

Space Name	Parent Floor	Activity Desc.	Infiltration Method	Infiltration Schedule	A-C Air Changes/hr	A-C Infiltration Flow (cfm/ft2)
1 WEST UPPER PERIMETER	EL1 Ground Flr	Office (E Air Change	ZGO-S1 (PSZ) P-In	0.34	0.0000	
2 SOUTH CORE	EL1 Ground Flr	Office (E Air Change	ZGO-S1 (PSZ) P-In	0.16	0.0000	
3 SOUTH UPPER LEFT PERI	EL1 Ground Flr	Office (E Air Change	ZGO-S1 (PSZ) P-In	0.30	0.0000	
4 WEST LOWER PERIMETER	EL1 Ground Flr	Office (E Air Change	ZGO-S1 (PSZ) P-In	0.30	0.0000	
5 NORTH PERIMETER	EL1 Ground Flr	Office (E Air Change	ZGO-S1 (PSZ) C-In	0.31	0.0000	
6 NORTH CORE	EL1 Ground Flr	Office (E Air Change	ZGO-S1 (PSZ) P-In	0.16	0.0000	
7 EAST UPPER PERIMETER	EL1 Ground Flr	Office (E Air Change	ZGO-S1 (PSZ) P-In	0.34	0.0000	
8 EAST LOWER PERIMETER	EL1 Ground Flr	Office (E Air Change	ZGO-S1 (PSZ) P-In	0.30	0.0000	
9 SOUTH UPPER LEFT PERI	EL1 Ground Flr	Office (E Air Change	ZGO-S1 (PSZ) P-In	0.30	0.0000	

Modeling Infiltration Example

The guidelines say to model infiltration in Openstudio/E+ using the ZoneInfiltration:DesignFlowRate object and the “Flow/ExteriorArea” Design Flow Rate Calculation Method. **This method excludes slab on grade floor area.**

Field	Units	Obj1	Obj2	Obj3	Obj4	Obj5	Obj6	Obj7	Obj8	Obj9	Obj10
Name		South Core	West Upper Peri	South Upper Left 2	West Lower	North Peri	North Core	East Upper	East Lower	South Upper Left	South Lower
Zone or ZoneList or Space or SpaceList Name		Thermal Zone 10	Thermal Zone 1	Thermal Zone 2	Thermal Zone 3	Thermal Zone 4	Thermal Zone 5	Thermal Zone 6	Thermal Zone 7	Thermal Zone 8	Thermal Zone 9
Schedule Name		Large Office Infil Qu	Large Office Infil Qu	Large Office Infil Qu	Large Office Infil Qu	Large Office Infil Qu	Large Office Infil Qu	Large Office Infil Qu	Large Office Infil Qu	Large Office Infil Qu	Large Office Infil Qu
Design Flow Rate Calculation Method		Flow/ExteriorArea	Flow/ExteriorArea	Flow/ExteriorArea	Flow/ExteriorArea	Flow/ExteriorArea	Flow/ExteriorArea	Flow/ExteriorArea	Flow/ExteriorArea	Flow/ExteriorArea	Flow/ExteriorArea
Design Flow Rate	f3/min										
Flow Rate per Floor Area	f3/min-ft2										
Flow Rate per Exterior Surface Area	f3/min-ft2	0.0336	0.0336	0.0336	0.0336	0.0336	0.0336	0.0336	0.0336	0.0336	0.0336
Air Changes per Hour	1/hr	0	0	0	0	0	0	0	0	0	0
Constant Term Coefficient		0	0	0	0	0	0	0	0	0	0
Temperature Term Coefficient											
Velocity Term Coefficient		0.224	0.224	0.224	0.224	0.224	0.224	0.224	0.224	0.224	0.224
Velocity Squared Term Coefficient											

IESVE- model based on a room/template level (Space Data) whereby a formula profile may be applied, referencing wind speed and or wind direction.

$$0.3 \text{ cfm}_{75\text{Pa}}/\text{sf} * 0.112 = 0.0336 \text{ cfm/sf at normal pressure}$$

Quiz #11

True or False: The same ACH value can be modeled for all thermal blocks in the energy model?

- A. True
- B. False

Quiz #11

True or False: The same ACH value can be modeled for all thermal blocks in the energy model?

A. True

B. False

The infiltration flow shall be assigned to the thermal blocks in proportion to the area of surfaces adjacent to exterior.

Quiz #12

True or False: Projects can model a leakage rate of 0.35 CFM/sf at 75 Pa in lieu of the actual testing results.

A. True

B. False

Quiz #12

True or False: Projects can model a leakage rate of 0.35 CFM/sf at 75 Pa in lieu of the actual testing results.

- A. True
- B. False

It is wise to use a conservative leakage rate of 0.35 when conducting TEDI modeling early in the design but ultimately the actual measured leakage will need to be modeled in the final design model.

Standardized Assumptions



- Included in **Tables 1-6 in the Schedules and Loads Guideline Supplement**. Parameters shall be modeled based on building use type and square footage, and thermal block use type. Parameters with standardized assumptions:
 - Interior lighting power and schedules.
 - Miscellaneous loads and schedules.
 - OA CFM ventilation rates and schedules (with exceptions).
 - Occupant densities and schedules.
 - Occupant heat gains
- Daylighting shall not be modeled in residential thermal blocks. In all other thermal blocks daylighting shall be modeled as prescribed.
- Default HVAC assumptions are in Sections 13.2.2-13.2.9

Standardized Model Inputs

Table of Contents

Table 1 Standardized Assumptions for Residential Buildings > 75,000-sf
Table 2 Standardized Assumptions for Residential Buildings <= 75,000-sf
Table 3: Standardized Assumptions for School Buildings > 75,000-sf
Table 4: Standardized Assumptions for School Buildings <= 75,000-sf
Table 5: Standardized Assumptions for Office, Fire Station, Library, Police Station, Post Office, Town Hall, and Other Building Types > 75,000-sf
Table 6: Standardized Assumptions for Office, Fire Station, Library, Police Station, Post Office, Town Hall, and Other Building Types <= 75,000-sf

OA CFM Example

Question: How do I determine what ventilation rates to model for a 100,000 ft² school project based on the TEDI guidelines requirements from Section 13.4.1 below?

Section 13.4.1 Minimum Ventilation Flow Rates

The minimum ventilation flow rate shall be modeled using the OA CFM/sf rate from [Tables 1-6 in the Schedules and Loads Guideline Supplement](#) for the building use type, area, and thermal block type.

Exception: The specified rate shall be modeled when both of the following applies:

- The specified ventilation rate exceeds the minimum requirements of applicable codes and standards by more than 135% AND
- The specified ventilation rate exceeds the OA CFM/sf value from Tables 1-6 of the Schedules and Loads Guidelines Supplement for the building use type.

OA CFM Example

Answer:

Table 3: Standardized Assumptions for School Buildings > 75,000-sf

Thermal Block Type	Schedule Index (Note 1)	Misc. Loads*	Lighting Power	Ventilation Rate	Occupant Density	Occupant Heat Gain	
		W/sf	W/sf	CFM/sf	sf/Person	Btu/h-person	
						Sensible	Latent
Cafeteria/kitchen**	E	15.5	0.52	1.19	13.5	250	160
Gymnasium	F	0.46	0.85	0.5	143	250	160
Auditorium	G	0.46	0.61	1.26	6.7	250	160
School	D	0.89	0.63	0.38	66	250	160

Occupancy Category	Floor Area	People Outdoor Air Rate	Area Outdoor Air Rate	Default Occupant Density	Ventilation Minimum Requirement		135% of Minimum Requirement		Ventilation Design Values		Does my Design Value Exceed Minimum Requirements by more than 135%?	Required Modeled Ventilation Rates	
					CFM	CFM/ft ²	CFM	CFM/ft ²	CFM	CFM/ft ²		CFM	CFM/ft ²
Units	Square Footage	CFM/Person	CFM/ft ²	#/1000 ft ²	Calculated	Calculated	Calculated	Calculated	-	-	No	K = J*A	J
Source of Information	From Drawings	From ASHRAE 62.1 Table 6-1			Calculated		Calculated		From Drawings		135%?	K = J*A	J
	A	B	C	D	$E = \frac{A * C + A * B * D}{1000}$	$F = E/A$	$G = E * 135\%$	$H = G/A$	-	-	No	K = J*A	J
Classrooms (age 9 plus)	65,000	10	0.12	35	30,550	0.47	41,243	0.63	38,425	0.59	No	24,700	0.38
Media center	5,000	10	0.12	25	1,850	0.37	2,498	0.50	2,050	0.41	No	1,900	0.38
Science laboratories	5,000	10	0.18	25	2,150	0.43	2,903	0.58	2,901	0.58	No	1,900	0.38
Computer lab	7,500	10	0.12	25	2,775	0.37	3,746	0.50	3,201	0.43	No	2,850	0.38
Corridors	17,500		0.06		1,050	0.06	1,418	0.08	1,375	0.08	No	6,650	0.38
Total	100,000				38,375	0.38	51,806	0.52	47,952	0.48	-	38,000	0.38

Minimum required outdoor air and specified ventilation rates shall be documented as described in Section C103.2 #16.

Quiz #13

Select which of the following model inputs are the same across all office buildings modeled for TEDI compliance in all circumstances?

- A. Lighting W/sf and schedules
- B. Miscellaneous equipment W/sf and schedules
- C. Occupant density and schedules
- D. Ventilation rate CFM/sf

Quiz #13

Select which of the following model inputs are the same across all office buildings modeled for TEDI compliance in all circumstances?

- A. Lighting W/sf and schedules
- B. Miscellaneous equipment W/sf and schedules
- C. Occupant density and schedules
- D. Ventilation rate CFM/sf

Cafeteria/Kitchen Example

Question: What do I model for the loads and schedules for a 15,000 ft² kitchen/cafeteria in a 250,000 ft² school project?

Table 3: Standardized Assumptions for School Buildings > 75,000-sf

Thermal Block Type	Schedule Index (Note 1)	Misc. Loads*	Lighting Power	Ventilation Rate	Occupant Density	Occupant Heat Gain	
						Btu/h-person	
						Sensible	Latent
Cafeteria/kitchen**	E	15.5	0.52	1.19	13.5	250	160
Gymnasium	F	0.46	0.85	0.5	143	250	160
Auditorium	G	0.46	0.61	1.26	6.7	250	160
School	D	0.89	0.63	0.38	66	250	160

* Use a sensible fraction of 1.0 and a latent fraction of 0.0 for all thermal blocks except model Cafeteria with a 0.25 latent and 0.75 sensible fraction.

** Applies to cafeterias/kitchens less than or equal to 9,040 sf. For cafeterias/kitchens greater than 9,040 sf model use the following equations, where cafeteria,kitchen sf = the square footage of the cafeteria/kitchen area:

Misc. Loads W/sf = $[140,120 + ((\text{cafeteria,kitchen sf} - 9,040) * 2.33)] / (\text{cafeteria,kitchen sf})$

Lighting Power W/sf = $[4,700 + ((\text{cafeteria,kitchen sf} - 9,040) * 0.48)] / (\text{cafeteria,kitchen sf})$

Ventilation Rate CFM/sf = $[10,761 + ((\text{cafeteria,kitchen sf} - 9,040) * 0.45)] / (\text{cafeteria,kitchen sf})$

Occupant Density sf/person = $[122,075 + ((\text{cafeteria,kitchen sf} - 9,040) * 58.9)] / (\text{cafeteria,kitchen sf})$

Schedules are modeled the same for all cafeteria/kitchens.

Cafeteria/Kitchen Example

Answer:

	First coefficient	Last coefficient	Kitchen/caf�� ft ²	Value to Model
Variable ID:	A	B	C	$=(A+((C-9,040)*B))/C$
Misc. Loads W/sf	140,120	2.33	15,000	10.3
Lighting Power W/sf	4,700	0.48	15,000	0.50
Ventilation Rate CFM/sf	10,761	0.45	15,000	0.90
Occupancy Density sf/Person	122,075	58.9	15,000	31.5

Table 3: Standardized Assumptions for School Buildings > 75,000-sf

Thermal Block Type	Schedule Index (Note 1)	Misc. Loads*	Lighting Power	Ventilation Rate	Occupant Density	Occupant Heat Gain	
						Btu/h-person	
						Sensible	Latent
Cafeteria/kitchen**	E	15.5	0.52	1.19	13.5	250	160
Gymnasium	F	0.46	0.85	0.5	143	250	160
Auditorium	G	0.46	0.61	1.26	6.7	250	160
School	D	0.89	0.63	0.38	66	250	160

* Use a sensible fraction of 1.0 and a latent fraction of 0.0 for all thermal blocks except model Cafeteria with a 0.25 latent and 0.75 sensible fraction.

** Applies to cafeterias/kitchens less than or equal to 9,040 sf. For cafeterias/kitchens greater than 9,040 sf model use the following equations, where cafeteria,kitchen sf = the square footage of the cafeteria/kitchen area:

Misc. Loads W/sf = $[140,120 + ((\text{cafeteria,kitchen sf} - 9,040) * 2.33)] / (\text{cafeteria,kitchen sf})$

Lighting Power W/sf = $[4,700 + ((\text{cafeteria,kitchen sf} - 9,040) * 0.48)] / (\text{cafeteria,kitchen sf})$

Ventilation Rate CFM/sf = $[10,761 + ((\text{cafeteria,kitchen sf} - 9,040) * 0.45)] / (\text{cafeteria,kitchen sf})$

Occupant Density sf/person = $[122,075 + ((\text{cafeteria,kitchen sf} - 9,040) * 58.9)] / (\text{cafeteria,kitchen sf})$

HVAC Modeling Requirements Reminder



HVAC Option 1: Model default HVAC system prescribed in the TEDI Technical Guidelines

- Required for buildings and areas within the building for which HVAC systems are not designed and are not shown on the construction documents.
- Allowed for all other buildings.

HVAC Option 2: Model as-designed HVAC Systems and Controls

- Allowed for projects where an HVAC system has been designed and submitted with design documents
- The modeled HVAC systems must be consistent with design documents with the following exceptions (this also applies to Option 1):
 - Airflows and heating and cooling capacities must be auto-sized using a prescribed methodology.
 - Modeled ventilation rates must be determined as follows:
 - As specified if the specified rate (1) exceeds the prescribed ventilation rate AND (2) exceeds the minimum code requirements by more than 135%,
 - Prescribed ventilation rate for the building use type in all other cases

Note: Minimum required outdoor air and specified ventilation rates shall be documented as described in Section C103.2 #16.

HVAC Option 1: Heating and Cooling System Type

The modeled heating and cooling system types shall be determined using Table 1 based on the building type and the total modeled floor area. Table 2 provides additional details for each system type.

Building Type	Heating/Cooling System Type
Office, fire station, library, police station, post office, town hall >= 125,000-sf	System 2 FCU
Office, fire station, library, police station, post office, town hall between 75,000 & 125,000-sf	System 2 FCU
Office, fire station, library, police station, post office, town hall <= 75,000-sf	System 1 ASHP
K-12 School >= 125,000-sf	System 2 FCU
K-12 School between 75,000 and 125,000-sf	System 2 FCU
K-12 School <= 75,000-sf	System 1 ASHP
Residential multifamily and dormitory >= 125,000-sf	System 3 WSHP
Residential multifamily and dormitory between 75,000 and 125,000-sf	System 1 ASHP
Residential multifamily and dormitory <= 75,000-sf	System 1 ASHP
All other >= 125,000-sf	System 2 FCU
All other between 75,000 and 125,000-sf	System 2 FCU
All other <= 75,000-sf	System 1 ASHP

Table 1: Heating and Cooling System Types by Building Type

System Number	System Type	Fan Control	Cooling Type	Heating Type
System 1 ASHP	Air source heat pump	Constant volume	Direct expansion	Electric heat pump
System 2 FCU	4-Pipe fan coil units with CHW and HW		Chilled water	Hot-water electric boiler
System 3 WSHP	Water source heat pump		Direct expansion	Electric heat pump, condenser water loop served by electric boiler

Table 2: Heating and Cooling System Details

Exception: K-12 school cafeterias (including dining and food preparation areas), auditoriums, and gymnasiums shall be modeled with variable volume single zone system that has same heating and cooling type as the remainder of the building.

HVAC Option 1

Mechanical Ventilation Systems

- Mechanical ventilation shall be provided by a dedicated outdoor air system (DOAS), decoupled from the system that provides heating and cooling.

Exception: Single zone systems modeled following Section 13.2.1 Exception (a) shall be modeled as also providing mechanical ventilation to the thermal block (K-12 school cafeterias (including dining and food preparation areas), auditoriums, and gymnasiums)

HVAC Option 1

Mechanical Ventilation Systems

- Mechanical ventilation shall be provided by a dedicated outdoor air system (DOAS), decoupled from the system that provides heating and cooling. Exception: Single zone systems modeled following Section 13.2.1 Exception (a) shall be modeled as also providing mechanical ventilation to the thermal block (K-12 school cafeterias (including dining and food preparation areas), auditoriums, and gymnasiums)
- Demand control ventilation shall not be modeled.

HVAC Option 1

Mechanical Ventilation Systems

- Mechanical ventilation shall be provided by a dedicated outdoor air system (DOAS), decoupled from the system that provides heating and cooling. Exception: Single zone systems modeled following Section 13.2.1 Exception (a) shall be modeled as also providing mechanical ventilation to the thermal block (K-12 school cafeterias (including dining and food preparation areas), auditoriums, and gymnasiums)
- Demand control ventilation shall not be modeled.
- Exhaust air energy recovery effectiveness shall be modeled as specified. The modeled controls shall allow bypassing energy recovery to permit air economizer operation and allow free cooling when outdoor air conditions are favorable. Controls shall be modeled to prevent overheating or overcooling of the mixed/supply air by the system.

HVAC Option 1

Mechanical Ventilation Systems

- Mechanical ventilation shall be provided by a dedicated outdoor air system (DOAS), decoupled from the system that provides heating and cooling. Exception: Single zone systems modeled following Section 13.2.1 Exception (a) shall be modeled as also providing mechanical ventilation to the thermal block (K-12 school cafeterias (including dining and food preparation areas), auditoriums, and gymnasiums)
- Demand control ventilation shall not be modeled.
- Exhaust air energy recovery effectiveness shall be modeled as specified. The modeled controls shall allow bypassing energy recovery to permit air economizer operation and allow free cooling when outdoor air conditions are favorable. Controls shall be modeled to prevent overheating or overcooling of the mixed/supply air by the system.
- DOAS systems shall be modeled with preheating and precooling coils of the same type as modeled for the space conditioning heating and cooling systems. Exception: Projects modeling System 3 to provide heating and cooling shall model the DOAS system(s) providing minimum outdoor air requirements with an electric resistance heating coil and DX cooling coil.

HVAC Option 1

Mechanical Ventilation Systems

- Mechanical ventilation shall be provided by a dedicated outdoor air system (DOAS), decoupled from the system that provides heating and cooling. Exception: Single zone systems modeled following Section 13.2.1 Exception (a) shall be modeled as also providing mechanical ventilation to the thermal block (K-12 school cafeterias (including dining and food preparation areas), auditoriums, and gymnasiums)
- Demand control ventilation shall not be modeled.
- Exhaust air energy recovery effectiveness shall be modeled as specified. The modeled controls shall allow bypassing energy recovery to permit air economizer operation and allow free cooling when outdoor air conditions are favorable. Controls shall be modeled to prevent overheating or overcooling of the mixed/supply air by the system.
- DOAS systems shall be modeled with preheating and precooling coils of the same type as modeled for the space conditioning heating and cooling systems. Exception: Projects modeling System 3 to provide heating and cooling shall model the DOAS system(s) providing minimum outdoor air requirements with an electric resistance heating coil and DX cooling coil.
- The DOAS shall not heat supply air above 60°F when representative building loads or outdoor air temperature indicate that the majority of zones require cooling.
- The DOAS shall not cool supply air below 70°F when representative building loads or outdoor air temperature indicate that the majority of zones require heating.

HVAC Option 1

Mechanical Ventilation Systems

- Mechanical ventilation shall be provided by a dedicated outdoor air system (DOAS), decoupled from the system that provides heating and cooling. Exception: Single zone systems modeled following Section 13.2.1 Exception (a) shall be modeled as also providing mechanical ventilation to the thermal block (K-12 school cafeterias (including dining and food preparation areas), auditoriums, and gymnasiums)
- Demand control ventilation shall not be modeled.
- Exhaust air energy recovery effectiveness shall be modeled as specified. The modeled controls shall allow bypassing energy recovery to permit air economizer operation and allow free cooling when outdoor air conditions are favorable. Controls shall be modeled to prevent overheating or overcooling of the mixed/supply air by the system.
- DOAS systems shall be modeled with preheating and precooling coils of the same type as modeled for the space conditioning heating and cooling systems. Exception: Projects modeling System 3 to provide heating and cooling shall model the DOAS system(s) providing minimum outdoor air requirements with an electric resistance heating coil and DX cooling coil.
- The DOAS shall not heat supply air above 60°F when representative building loads or outdoor air temperature indicate that the majority of zones require cooling.
- The DOAS shall not cool supply air below 70°F when representative building loads or outdoor air temperature indicate that the majority of zones require heating.
- No dehumidification controls shall be modeled.

HVAC Option 1

System Type Selection Example

Question: What default heating, cooling, and ventilation systems should be modeled for a 320,000 ft² K-12 school with a 34,000 ft² gymnasium, a 10,600 ft² auditorium, and a 9,040 ft² cafeteria, which includes a kitchen and dining area? Other space types include classrooms, lounges, corridors, restrooms, heated only storage rooms, mechanical rooms, and offices.



HVAC Option 1

System Type Selection Example

Answer: The following systems should be modeled:

Heating and cooling systems

- Based on Table 1, all school thermal blocks (including heated-only spaces) are modeled with heating and cooling provided by constant volume fan coil units with hot water and chilled water coils. (K-12 schools over 125,000 ft²)
- Based on Section 13.2.1 Exception (a), the gymnasium, auditorium, and cafeteria are modeled with single zone variable volume units with hot water and chilled water coils

Ventilation systems

- Based on Section 13.2.2 (a), school thermal blocks must be modeled with the dedicated outdoor air system (DOAS), de-coupled from the heating and cooling systems (i.e., OA provided to thermal zone separately from the heating and cooling system)
- Based on the exception to Section 13.2.2 (a), the gymnasiums, cafeterias, and auditoriums shall be modeled with OA provided via the heating and cooling system serving the associated thermal blocks.

Building Type	Heating/Cooling System Type
Office, fire station, library, police station, post office, town hall >= 125,000-sf	System 2 FCU
Office, fire station, library, police station, post office, town hall between 75,000 & 125,000-sf	System 2 FCU
Office, fire station, library, police station, post office, town hall <= 75,000-sf	System 1 ASHP
K-12 School >= 125,000-sf	System 2 FCU
K-12 School between 75,000 and 125,000-sf	System 2 FCU
K-12 School <= 75,000-sf	System 1 ASHP
Residential multifamily and dormitory >= 125,000-sf	System 3 WSHP
Residential multifamily and dormitory between 75,000 and 125,000-sf	System 1 ASHP
Residential multifamily and dormitory <= 75,000-sf	System 1 ASHP
All other >= 125,000-sf	System 2 FCU
All other between 75,000 and 125,000-sf	System 2 FCU
All other <= 75,000-sf	System 1 ASHP

Table 1: Heating and Cooling System Types by Building Type

HVAC Option 1

System Type Selection Example

Question: The as-designed HVAC systems in the previous example all include exhaust air energy recovery with an enthalpy recovery ratio of 75% except for the systems serving heated only storage rooms. How should energy recovery be modeled?



HVAC Option 1

System Type Selection Example

Question: The as-designed HVAC systems in the previous example all include exhaust air energy recovery with an enthalpy recovery ratio of 75% except for the system serving heated only storage room. How should energy recovery be modeled?

Answer: The following systems should be modeled:

Per Section 13. 2.2.c exhaust air energy recovery must be modeled as specified. Therefore, exhaust air energy recovery with the 75% enthalpy recovery ratio is modeled for the DOAS system serving school thermal blocks, and for the single zone variable volume systems serving gymnasium, auditorium, and cafeteria (typical model inputs for exhaust air energy recovery are sensible and latent effectiveness, these would be modeled per the design).

Exhaust air energy recovery is not modeled for the heated only thermal blocks because it is not specified for these areas. Note that these are modeled as both heated and cooled as there are no provisions for heating-only thermal blocks for a school project in Section 8.2. Also, following Section 8.3 (e) thermal blocks without energy recovery cannot be aggregated with thermal block with energy recovery specified.

Quiz #14

What heating and cooling system type should be modeled for a 25,000 square foot library?

- A. Air source heat pumps
- B. Fan coil units served by chiller and boiler
- C. Water source heat pumps
- D. Gas furnaces with DX cooling

Quiz #14

What heating and cooling system type should be modeled for a 25,000 square foot library?

- A. Air source heat pumps
- B. Fan coil units served by chiller and boiler
- C. Water source heat pumps
- D. Gas furnaces with DX cooling

Building Type	Heating/Cooling System Type
Office, fire station, library, police station, post office, town hall >= 125,000-sf	System 2 <i>FCU</i>
Office, fire station, library, police station, post office, town hall between 75,000 & 125,000-sf	System 2 <i>FCU</i>
Office, fire station, library, police station, post office, town hall <= 75,000-sf	System 1 <i>ASHP</i>
K-12 School >= 125,000-sf	System 2 <i>FCU</i>
K-12 School between 75,000 and 125,000-sf	System 2 <i>FCU</i>
K-12 School <= 75,000-sf	System 1 <i>ASHP</i>
Residential multifamily and dormitory >= 125,000-sf	System 3 <i>WSHP</i>
Residential multifamily and dormitory between 75,000 and 125,000-sf	System 1 <i>ASHP</i>
Residential multifamily and dormitory <= 75,000-sf	System 1 <i>ASHP</i>
All other >= 125,000-sf	System 2 <i>FCU</i>
All other between 75,000 and 125,000-sf	System 2 <i>FCU</i>
All other <= 75,000-sf	System 1 <i>ASHP</i>

Table 1: Heating and Cooling System Types by Building Type

DOAS Temperature Control eQuest

Example: Multifamily Building

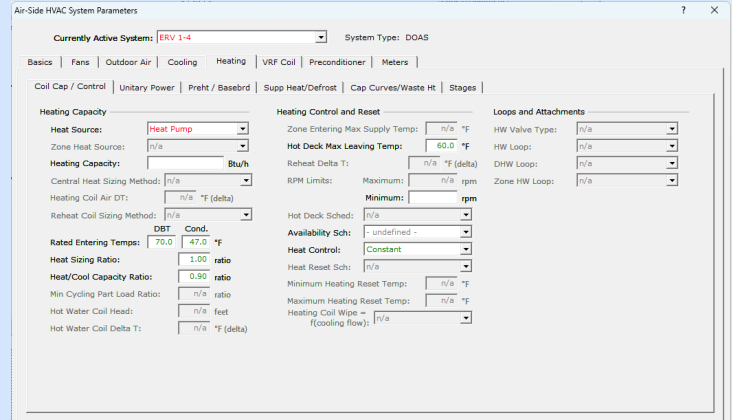
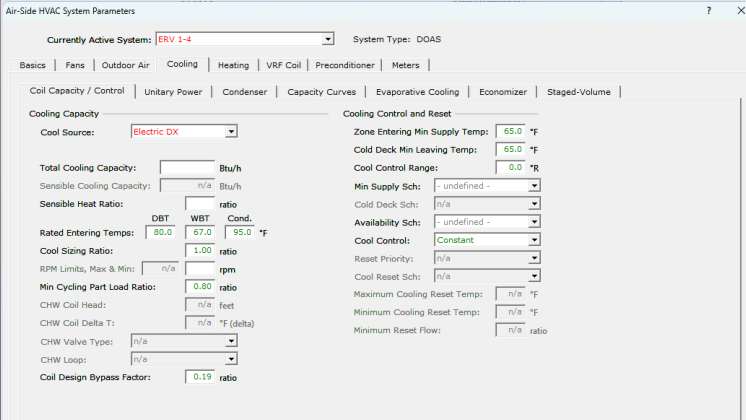

eQuest default DOAS supply air temperature setpoints

DOAS Temperature Control eQuest

Example

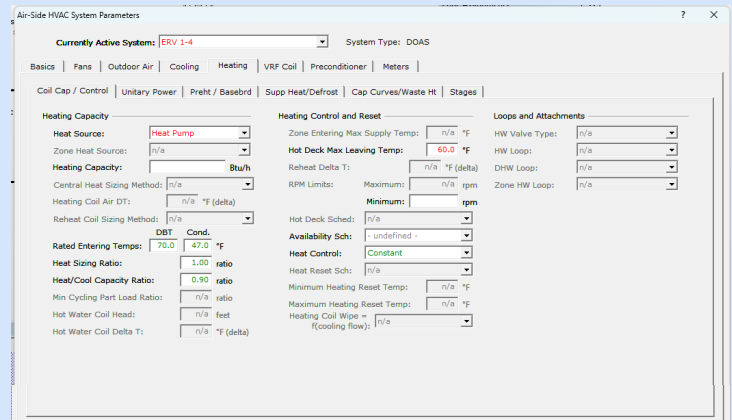
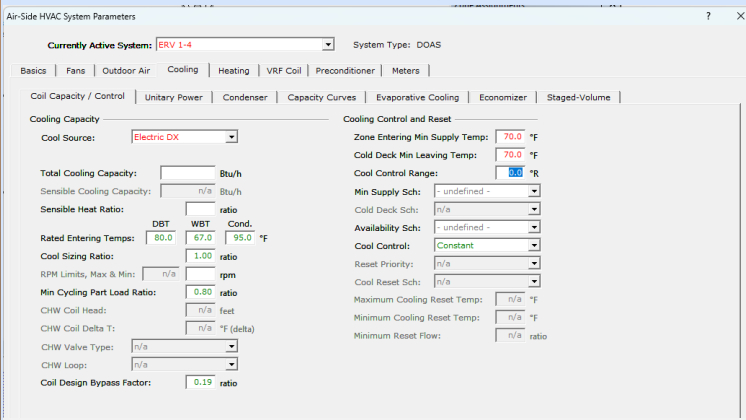

70°F min for cooling and 60°F max for heating

The DOAS shall not heat supply air above 60°F when representative building loads or outdoor air temperature indicate that the majority of zones require cooling.

The DOAS shall not cool supply air below 70°F when representative building loads or outdoor air temperature indicate that the majority of zones require heating.

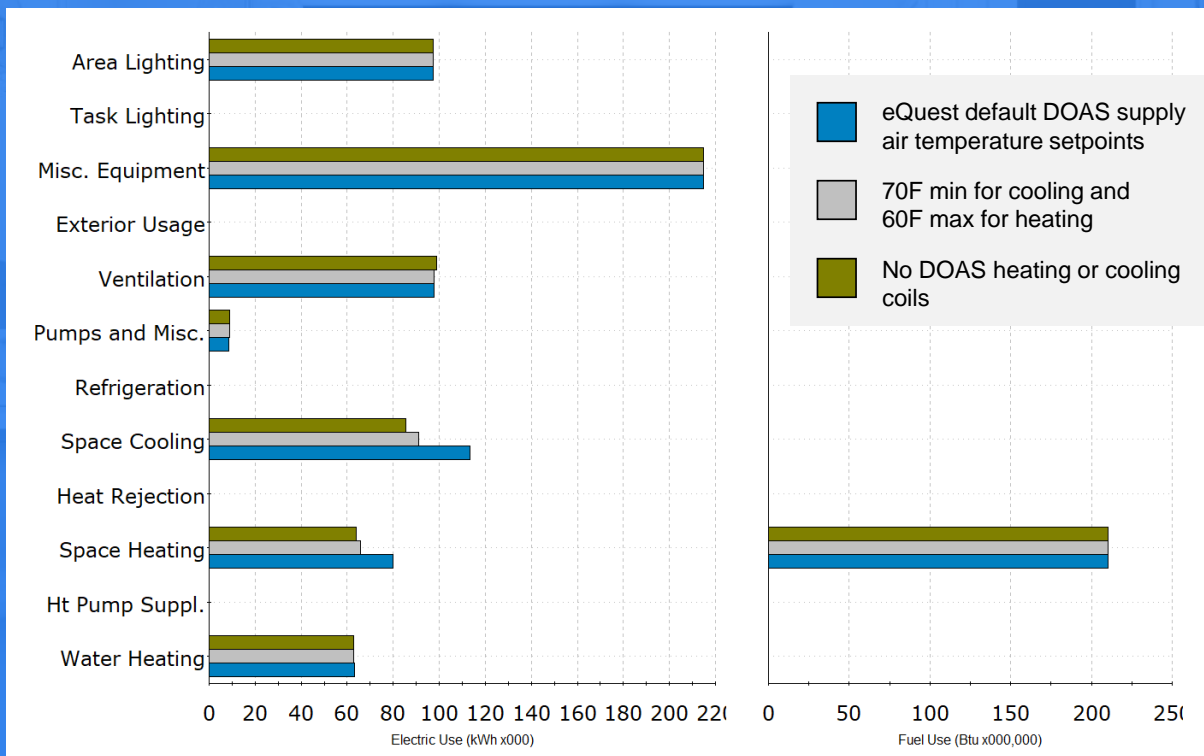

HVAC Option 1

Unitary Equipment Efficiency (13.2.4)

- Air source heat pumps shall be modeled with a cooling efficiency of 3.74 COPnfcolling and a heating efficiency of 3.66 COPnfheating at 47F DB.
- Water source heat pumps shall be modeled with a cooling efficiency of 4.4 COPnfcolling at an entering water temperature of 86F and a heating efficiency of 5.0 COPnfheating at an entering water temperature of 68F.

Coil Cap / Control | Unitary Power | Preht / Basebrd | Supp H

Heating Capacity

Heat Source: Heat Pump

Zone Heat Source: n/a

Heating Capacity: Btu/h

Central Heat Sizing Method: n/a

Heating Coil Air DT: n/a °F (delta)

Reheat Coil Sizing Method: n/a

Rated Entering Temps: DBT 70.0, Cond. 47.0 °F

Air-Side HVAC System Parameters

Currently Active System: ERV 1-4 System Type: DOAS

Basics | Fans | Outdoor Air | Cooling | Heating | VRF Coil | Preconditioner | Meters

Coil Cap / Control | Unitary Power | Preht / Basebrd | Supp Heat/Defrost | Cap Curves/Waste Ht | Stages

Heating Electric Power

Heating Electric Input Ratio: 0.2732 Btu/Btu

Heating Electric Input Ratio Curves

f(t entering wetbulb, t outdoor drybulb): PVVT-Heat-EIR-fEDE

Low Speed Electric Input Ratio Curve

f(t entering wetbulb, t outdoor drybulb): n/a

$$\text{EIR} = 1/3.66 = 0.2732$$

HVAC Option 1

Fan System Operation (13.2.7)

Heating and cooling system fans that do not provide outside air to meet minimum ventilation requirements shall cycle on and off to meet heating and cooling loads.

DOAS fans shall operate continuously during occupied hours and remain off during unoccupied hours.

Heating and cooling system fans in single zone systems modeled following Section 13.2.1 Exception a that provide outside air to meet minimum ventilation requirements (e.g., systems serving cafeterias, auditoriums, and gymnasiums) shall operate continuously during occupied hours and shall cycle to meet heating and cooling loads during unoccupied hours.

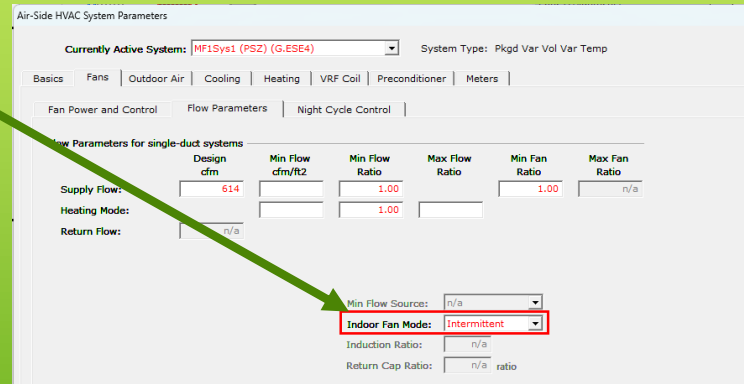

HVAC Option 1

System Fan Power (13.2.8)



Design fan power shall be modeled per Table 3 and Table 4 in the guidelines based on the building type, areas served, and the system type.

Table 3: Fan Power Modeling Requirements for Heating and Cooling Equipment

Building Type	Areas Served	Heating/Cooling System Type	Fan Power, kW/CFM
Office, fire station, library, police station, post office, town hall, K-12 school, and all other	All except gyms, cafeterias, auditoriums	System 1 and System 2	0.00024
Residential multifamily and dormitory	All	System 1	0.00012
Residential multifamily and dormitory	All	System 3	0.00017
K-12 school	Gyms, cafeterias, and auditoriums only	System 1 and System 2	0.00050

Table 4: Fan Power Modeling Requirements for DOAS

Building Type	Fan Power, kW/CFM
Office, fire station, library, police station, post office, town hall, K-12 school, and all other	0.00063
Residential multifamily and dormitory	0.0005

HVAC Option 1

System Fan Power (13.2.8)

Ventilation systems serving thermal blocks for which exhaust air energy recovery other than a coil runaround loop is specified in the proposed design shall be modeled with additional fan power determined as follows:

Table 4: Fan Power Modeling Requirements for DOAS

Building Type	Fan Power, kW/CFM
Office, fire station, library, police station, post office, town hall, K-12 school, and all other	0.00063
Residential multifamily and dormitory	0.0005

This additional fan power is required to be modeled per below. It is not optional.

1. For each airstream determine the pressure drop (PD) through the specified energy recovery device based on design documents and or manufacturer specification.
2. Calculate the additional brake horsepower required to be modeled
 $bhp = \text{sum of } (PD \times cfmD/4131)$
 $cfmD = \text{the cfm of each applicable air stream}$
3. Convert bhp to kW = $bhp \times 0.746/\text{fan motor efficiency}$
 Fan motor efficiency = the efficiency from ASHRAE 90.1 2019 Section 10 for the next motor size greater than the bhp.

HVAC Option 1

System Fan Power Example

Table 4: Fan Power Modeling Requirements for DOAS

Building Type	Fan Power, kW/CFM
Office, fire station, library, police station, post office, town hall, K-12 school, and all other	0.00063
Residential multifamily and dormitory	0.0005

Question: A multifamily project proposed design includes a central DOAS that serves all areas of the building that has an 80% sensible effectiveness, the pressure drop through each airstream (outdoor air and exhaust) is 1.35 in. of water. The outdoor air and exhaust CFM rates are 10,000 CFM each. What fan power is required to be modeled?

Answer: BHP = sum of $(PD \times cfmD/4131)$

$BHP = (1.35 \text{ inches of water} \times 10,000 \text{ CFM}/4131) + (1.35 \text{ inches of water} \times 10,000 \text{ CFM}/4131) = 6.54 \text{ BHP} \rightarrow \text{Section 10 motor efficiency} = 91\% \text{ (per 90.1 9019 Table 10.8-1)}$

Convert BHP to kW = $6.54 \text{ BHP} \times 0.746/91\% = 5.36 \text{ kW}$

$kW/CFM = 5.36 \text{ kW}/10,000 \text{ CFM} = 0.000536 \text{ kW/CFM}$

Total kW/CFM to model = $0.0005 \text{ kW/CFM (Table 4)} \times 10,000 \text{ CFM} + 5.36 \text{ kW} = 0.001036 \text{ kW/CFM}$
 $kW/CFM = 10.36 \text{ kW}/10,000 \text{ CFM} = 0.001036 \text{ kW/CFM}$

HVAC Option 1

System Fan Power Example

Table 4: Fan Power Modeling Requirements for DOAS

Building Type	Fan Power, kW/CFM
Office, fire station, library, police station, post office, town hall, K-12 school, and all other	0.00063
Residential multifamily and dormitory	0.0005

Question: A multifamily project proposed design includes a central DOAS that serves all areas of the building that has an 80% sensible effectiveness, the pressure drop through each airstream (outdoor air and exhaust) is 1.35 in. of water. The outdoor air and exhaust CFM rates are 10,000 CFM each. What fan power should be modeled?

Answer: BHP = sum of (PD × cfmD/4131)

$BHP = (1.35 \text{ inches of water} * 10,000 \text{ CFM}/4131) + (1.35 \text{ inches of water} * 10,000 \text{ CFM}/4131) = 6.54 \text{ BHP} \rightarrow \text{Section 10 motor efficiency} = 91\% \text{ (per 90.1 9019 Table 10.8-1)}$

Convert BHP to kW = $6.54 \text{ BHP} * 0.746/91\% = 5.36 \text{ kW}$

kW/CFM = $5.36 \text{ kW}/10,000 \text{ CFM} = 0.000536 \text{ kW/CFM}$

Total kW/CFM to model = $0.0005 \text{ kW/CFM (Table 4)} * 10,000 \text{ CFM} + 5.36 \text{ kW} = 10.36 \text{ kW}$

kW/CFM = $10.36 \text{ kW}/10,000 \text{ CFM} = 0.001036 \text{ kW/CFM}$

HVAC Option 1

System 2 and 3: HW, CHW, and Condenser Water Parameters (13.2.9)

Includes modeling parameters for:

- Design and operating temperature setpoints and reset schedules
- Pumping power and loop configuration
- Type and efficiency of boilers, chillers, and cooling towers

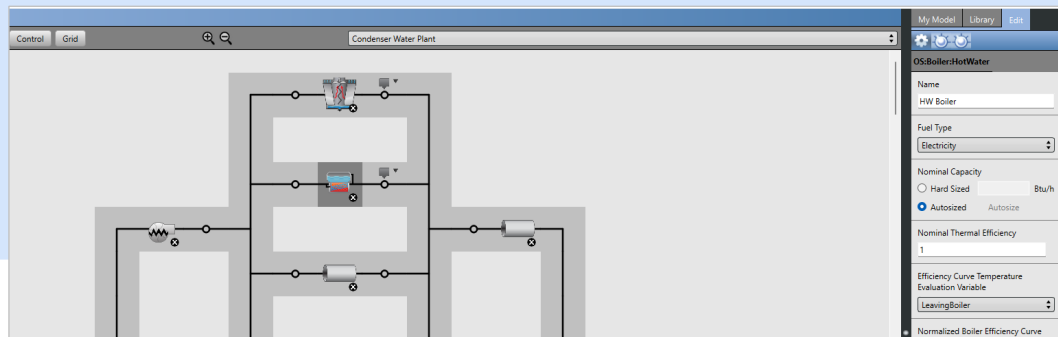
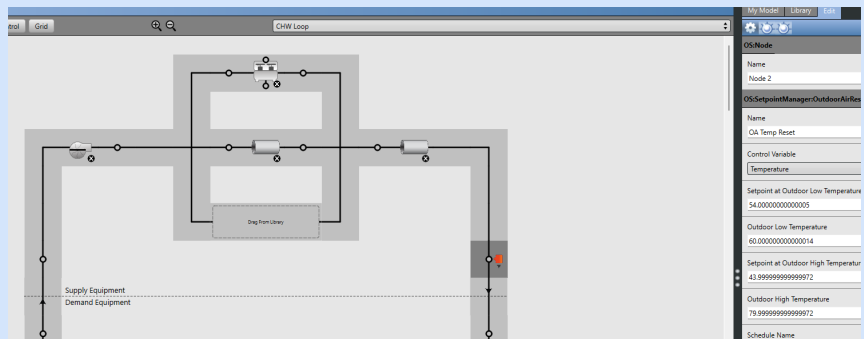
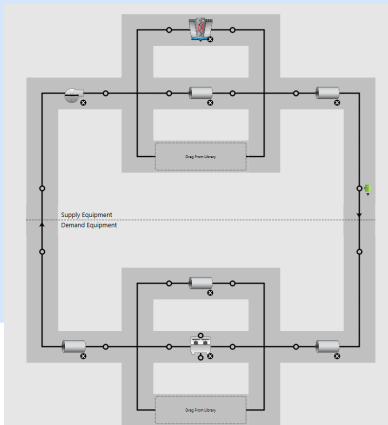

HVAC Option 2 Modeling As-Designed HVAC Systems (13.3)

Where an HVAC system has been designed and submitted with design documents, the HVAC model shall be consistent with design documents including all components and controls except as prescribed in Section 13.4 and in the Schedule and Loads Guidelines Supplement.

Exception: System air flows and heating and cooling capacities shall be auto sized per Section 13.2.4.

HVAC Option 2 Modeling As-Designed HVAC Systems: Modeling Efficiency

Where efficiency ratings include supply fan energy, the efficiency rating shall be adjusted to remove the supply fan energy from the efficiency rating.

The systems shall be modeled using manufacturers' full- and part load data for the HVAC system without fan power.

- Supply fan power at AHRI rating conditions must be extracted from HVAC system efficiency ratings.
- The actual power of the specified fan must be modeled.

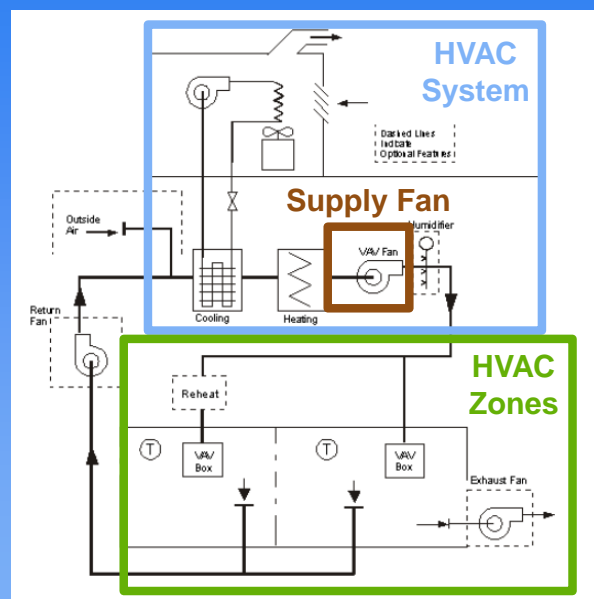

HVAC Option 2

Modeling As-Designed HVAC Systems: Modeling Efficiency

$$EER = \frac{\text{Net Cooling [Btu/h]}}{\text{Total Input Power [W]}}$$

$$\text{Indoor Fan Power [W]} = \frac{\text{Gross Cooling [Btu/h]} - \text{Net Cooling [Btu/h]}}{3.413 [\text{Btu/h} \times \text{W}]}$$

$$COP_{\text{nfcooling}} = \frac{\text{Gross Cooling [Btu/h]}}{(\text{Total Input Power [W]} - \text{Indoor Fan Power [W]}) \times 3.413 [\text{Btu/h} \times \text{W}]}$$

- All the inputs above are from the manufacturer's catalogs for AHRI Rated conditions.
- Equations are from the 90.1 User Manual.

HVAC Option 2

Modeling As-Designed HVAC Systems: Modeling Efficiency Example



General Data

Table 2. General data - 6 to 10 tons with eFlex™ and eDrive™ technology (208/230 volt)

	6 Tons	7.5 Tons	8.5 Tons	10 Tons
	T/YZC072F3	T/YZC090F3	T/YZC102F3	T/YZC120F3
Cooling Performance^(a)				
Gross Cooling Capacity - Full Load	71,000	92,000	103,000	117,000
EER/IEER ^(b)	12.8/23.2	12.8/22.4	12.6/22.5	12.1/23.0
Nominal cfm/AHRI Rated cfm	2,400/2,400	3,000/2,850	3,400/2,975	4,000/4,000
AHRI Net Cooling Capacity - Full Load	70,000	90,000	99,000	114,000
System Power (kW)	5.47	7.03	7.86	9.42

			T/YZC102F3
Net Cooling Capacity	Btu/hr	A	99,000
EER		B	12.6
Total Packaged Unit Power	W	C=A/B	7,857
Gross cooling capacity	Btu/hr	D	103,000
Supply fan power	W	E= (D-A)/3.412	1172
COP _{nfcool}		F=D/3.412/(C-E)	4.52
EIR		1/F	0.2214

OA Modeling Requirements

The minimum ventilation flow rate shall be modeled using the OA CFM/sf rate from Tables 1-6 of the Schedules and Loads Guidelines Supplement for the building use type.

Exception: The specified rate shall be modeled when both of the following applies:

- The specified ventilation rate exceeds the minimum requirements of applicable codes and standards by more than 135% AND
- The specified ventilation rate exceeds the OA CFM/sf value from Tables 1-6 of the Schedules and Loads Guidelines Supplement for the building use type.

Occupancy Category	Floor Area	People Outdoor Air Rate	Area Outdoor Air Rate	Default Occupant Density	Ventilation Minimum Requirement		135% of Minimum Requirement		Ventilation Design Values		Does my Design Value Exceed Minimum Requirements by more than 135%?	Required Modeled Ventilation Rates	
					CFM	CFM/ft ²	CFM	CFM/ft ²	CFM	CFM/ft ²		CFM	CFM/ft ²
Units	Square Footage	CFM/Person	CFM/ft ²	#/1000 ft ²	Calculated		Calculated		From Drawings		From the Schedule and Loads Guidelines Supplement	CFM	CFM/ft ²
Source of Information	From Drawings	From ASHRAE 62.1 Table 6-1			Calculated		Calculated		From Drawings			K = J * A	J
	A	B	C	D	$E = A * C * A * B * D / 1000$	$F = E / A$	$G = E * 135\%$	$H = G / A$	-	-			
Classrooms (age 9 plus)	65,000	10	0.12	35	30,550	0.47	41,243	0.63	38,425	0.59	No	24,700	0.38
Media center	5,000	10	0.12	25	1,850	0.37	2,498	0.50	2,050	0.41	No	1,900	0.38
Science laboratories	5,000	10	0.18	25	2,150	0.43	2,903	0.58	2,901	0.58	No	1,900	0.38
Computer lab	7,500	10	0.12	25	2,775	0.37	3,746	0.50	3,201	0.43	No	2,850	0.38
Corridors	17,500		0.06		1,050	0.06	1,418	0.08	1,375	0.08	No	6,650	0.38
Total	100,000				38,375	0.38	51,806	0.52	47,952	0.48	-	38,000	0.38

Minimum required outdoor air and specified ventilation rates shall be documented as described in Section C103.2 #16.

Quiz #15

An 60,000 sf office building has a design ventilation rate of 0.17 CFM/sf. The calculated minimum code required ventilation rate is 0.11 CFM/sf, what ventilation rate should be modeled?

- A. 0.17 CFM/sf
- B. 0.11 CFM/sf
- C. 0.18 CFM/sf
- D. 0.15 CFM/sf

Table 5: Standardized Assumptions for Office, Fire Station, Library, Police Station, Post Office, Town Hall, and Other Building Types > 75,000-sf

Thermal Block Type	Schedule Index (Note 1)	Misc. Loads*	Lighting Power	Ventilation Rate	Occupant Density	Occupant Heat Gain	
		W/sf	W/sf	CFM/sf	sf/Person	Sensible	Latent
Office, Fire Station, Library, Police Station, Post Office, Town Hall, and Other	H	0.75	0.64	0.18	205	250	160

* Use a sensible fraction of 1.0 and a latent fraction of 0.0 for all thermal blocks.

Quiz #15

An 60,000 sf office building has a design ventilation rate of 0.17 CFM/sf. The calculated minimum code required ventilation rate is 0.11 CFM/sf, what ventilation rate should be modeled?

- A. 0.17 CFM/sf
- B. 0.11 CFM/sf
- C. 0.18 CFM/sf, even though the design ventilation rate exceeds the minimum required rate by more than 135% ($0.11 * 135\% = 0.149$ CFM/sf), because the rate is less than the 0.18 CFM/sf from the Schedule and Loads Guidelines Supplement the value from the Schedule and Loads Guidelines Supplement is modeled. Only if it exceeded this value would the as-designed value be modeled.
- D. 0.15 CFM/sf

Table 5: Standardized Assumptions for Office, Fire Station, Library, Police Station, Post Office, Town Hall, and Other Building Types > 75,000-sf

Thermal Block Type	Schedule Index (Note 1)	Misc. Loads*	Lighting Power	Ventilation Rate	Occupant Density	Occupant Heat Gain	
						Btu/h-person	
						Sensible	Latent
Office, Fire Station, Library, Police Station, Post Office, Town Hall, and Other	H	0.75	0.64	0.18	205	250	160

* Use a sensible fraction of 1.0 and a latent fraction of 0.0 for all thermal blocks.

Quiz #16

An 60,000 sf office building has a design ventilation rate of 0.30 CFM/sf. The calculated minimum code required ventilation rate is 0.23 CFM/sf, what ventilation rate should be modeled?

- A. 0.30 CFM/sf
- B. 0.23 CFM/sf
- C. 0.18 CFM/sf
- D. 0.22 CFM/sf

Table 5: Standardized Assumptions for Office, Fire Station, Library, Police Station, Post Office, Town Hall, and Other Building Types > 75,000-sf

Thermal Block Type	Schedule Index (Note 1)	Misc. Loads*	Lighting Power	Ventilation Rate	Occupant Density	Occupant Heat Gain	
						Btu/h-person	
						Sensible	Latent
Office, Fire Station, Library, Police Station, Post Office, Town Hall, and Other	H	0.75	0.64	0.18	205	250	160

* Use a sensible fraction of 1.0 and a latent fraction of 0.0 for all thermal blocks.

Quiz #16

An 60,000 sf office building has a design ventilation rate of 0.30 CFM/sf. The calculated minimum code required ventilation rate is 0.23 CFM/sf, what ventilation rate should be modeled?

- A. 0.30 CFM/sf
- B. 0.23 CFM/sf
- C. 0.18 CFM/sf

0.23 CFM/sf * 135% = 0.31 CFM/sf. Because the design value does not exceed minimum code requirements by more than 135% the value from the Schedules and Loads Guidelines Supplement is modeled.

- A. 0.22 CFM/sf

HVAC Option 2 Modeling As-Designed HVAC Systems: Demand Controlled Ventilation

The minimum ventilation rate shall be modeled as follows for HVAC systems with demand-controlled ventilation:

- At the peak occupancy, VRmax shall equal the OA CFM/sf from Tables 1-6 of the Schedules and Loads Guidelines Supplement for the building use type or the specified ventilation rate if the rate exceeds minimum code requirements by more than 135%, whichever is greater.
- At the minimum occupancy, the minimum ventilation rate shall be no less than VRmin.

$$VR_{max} = CFM_{FPP} \times Per \times OF_{max} + A_{flow}$$

$$VR_{min} = CFM_{FPP} \times Per \times OF_{min} + A_{flow}$$

Table 5: Standardized Assumptions for Office, Fire Station, Library, Police Station, Post Office, Town Hall, and Other Building Types > 75,000-sf

Thermal Block Type	Schedule Index (Note 1)	Misc. Loads*	Lighting Power	Ventilation Rate	Occupant Density sf/Person	Occupant Heat Gain	
		W/sf	W/sf	CFM/sf		Btu/h-person	
						Sensible	Latent
Office, Fire Station, Library, Police Station, Post Office, Town Hall, and Other	H	0.75	0.64	0.18	205	250	160

* Use a sensible fraction of 1.0 and a latent fraction of 0.0 for all thermal blocks.

HVAC Option 2

Modeling As-Designed HVAC Systems: Demand Controlled Ventilation

Where:

$$VR_{max} = CFMFPP \times Per \times OF_{max} + A_{flow}$$

$$VR_{min} = CFMFPP \times Per \times OF_{min} + A_{flow}$$

VR_{max} = maximum ventilation rate, CFM/ft² accounting for the occupant ventilation requirement per person and per area separately.

VR_{min} = minimum ventilation rate, CFM/ft² accounting for the occupant ventilation requirement per person and per area separately.

HVAC Option 2

Modeling As-Designed HVAC Systems: Demand Controlled Ventilation

Where:

$$VR_{max} = CFMFPP \times Per \times OF_{max} + A_{flow}$$

$$VR_{min} = CFMFPP \times Per \times OF_{min} + A_{flow}$$

VR_{max} = maximum ventilation rate, CFM/ft² accounting for the occupant ventilation requirement per person and per area separately.

VR_{min} = minimum ventilation rate, CFM/ft² accounting for the occupant ventilation requirement per person and per area separately.

CFMFPP = flow per person, CFM/person from design documents or adjusted value to achieve a VR_{max} per the requirements of 13.3.d.i CFM/FT².

Per = inverse of the occupant density from Tables 1-6 of the Schedules and Loads Guidelines Supplement for the building use type.

HVAC Option 2

Modeling As-Designed HVAC Systems: Demand Controlled Ventilation

Where:

$$VR_{max} = CFMFPP \times Per \times OF_{max} + A_{flow}$$

$$VR_{min} = CFMFPP \times Per \times OF_{min} + A_{flow}$$

VR_{max} = maximum ventilation rate, CFM/ft² accounting for the occupant ventilation requirement per person and per area separately.

VR_{min} = minimum ventilation rate, CFM/ft² accounting for the occupant ventilation requirement per person and per area separately.

CFMFPP = flow per person, CFM/person from design documents or adjusted value to achieve a VR_{max} per the requirements of 13.3.d.i CFM/FT².

Per = inverse of the occupant density from Tables 1-6 of the Schedules and Loads Guidelines Supplement for the building use type.

OF_{max} = the maximum hourly fraction for the occupancy schedule from the Schedules and Loads Guidelines Supplement for the building use type.

OF_{min} = the minimum hourly fraction for the occupancy schedule from the Schedules and Loads Guidelines Supplement for the building use type.

HVAC Option 2

Modeling As-Designed HVAC Systems: Demand Controlled Ventilation

Where:

$$VR_{max} = CFMFPP \times Per \times OF_{max} + A_{flow}$$

$$VR_{min} = CFMFPP \times Per \times OF_{min} + A_{flow}$$

VR_{max} = maximum ventilation rate, CFM/ft² accounting for the occupant ventilation requirement per person and per area separately.

VR_{min} = minimum ventilation rate, CFM/ft² accounting for the occupant ventilation requirement per person and per area separately.

CFMFPP = flow per person, CFM/person from design documents or adjusted value to achieve a VR_{max} per the requirements of 13.3.d.i CFM/FT².

Per = inverse of the occupant density from Tables 1-6 of the Schedules and Loads Guidelines Supplement for the building use type.

OF_{max} = the maximum hourly fraction for the occupancy schedule from the Schedules and Loads Guidelines Supplement for the building use type.

OF_{min} = the minimum hourly fraction for the occupancy schedule from the Schedules and Loads Guidelines Supplement for the building use type.

A_{flow} (ventilation requirement/area) = minimum ventilation rate per unit area from design documents.

HVAC Option 2

Modeling As-Designed HVAC Systems: Demand Controlled Ventilation Example

Question: A 150,000 ft² school is demonstrating compliance with TEDI by modeling the specified HVAC systems as allowed in Section 13.1 b (i). The design includes demand-controlled ventilation in classrooms based on 10 CFM/person and 0.16 CFM/ft² design criteria. How should classroom ventilation be modeled?

Answer: Step 1: Calculate VR_{max} and VR_{min} for each classroom zone for which demand control ventilation is specified using the equations in Section 13.3 d and values from Schedules and Loads Guidelines Supplemental Workbook and design.

OF_{max} = 0.95 (“D-School” tab, the maximum value from School_BLDG_OCC_SCH)

OF_{min} = 0.15 (“D-School” tab, the minimum value from School_BLDG_OCC_SCH)

Per (occ/ft²) = 0.015 (Standardized Model Inputs tab, Table 3, School row, inverse of Occupant Density column, 1/66=0.015)

CFMFPP (CFM/per) = 10 (from design documents)

Aflow (CFM/FT²) = 0.16 (from design documents)

VR_{max} = 10 * 0.015 * 0.95 + 0.16 = 0.3 CFM/FT² (CFMFPP x Per x OF_{max} + Aflow)

VR_{min} = 10 * 0.015 * 0.15 + 0.16 = 0.18 CFM/FT² (CFMFPP x Per x OF_{min} + Aflow)

HVAC Option 2

Modeling As-Designed HVAC Systems: Demand Controlled Ventilation Example

Answer continued: Step 2: Check if VR_{max} meets the requirement of 13.3.d.i. which stipulates that VR_{max} must be modeled as equal to OA CFM/sf from prescribed in Schedules and Loads Guidelines Supplement or the specified ventilation rate if the rate exceeds minimum code requirements by more than 135%, whichever is greater.

OA (CFM/ft²) = 0.38 (“Standardized Model Inputs” tab, Table 3, School row, Ventilation Rate column)

Based on calculations in Step 1, VR_{max} is less than the OA CFM/ft², so the modeled CFMFPP must be adjusted up as follows:

Rearrange: $CFMFPP * 0.015 * 0.95 + 0.16 = 0.38 \text{ CFM/ft}^2 \rightarrow$

$CFMFPP = (0.38 - 0.16) / (0.015 * 0.95) = 15 \text{ CFM/PP}$

Step 3: Recalculate VR_{min} using the adjusted CFMFPP:

VR_{min} = 15 * 0.015 * 0.15 + 0.16 = 0.19 CFM/ft²

The modeled ventilation in classrooms must be modeled as varying from VR_{min} = 0.19 CFM/ft² to VR_{max} = 0.38 CFM/ft² based on occupancy using the 15 CFM/Per Person value.

Quiz #17

A 21,000 ft² office building is modeling as-designed HVAC systems for TEDI compliance. The design specifies demand-controlled ventilation (DCV) for the office zones, when determining the VR_{max} and VR_{min} values to model what should be the value of Per in the equation below (Per = occupant density)

- A. 179 sf/person
- B. 0.0056 people/sf
- C. As-designed value.
- D. DCV is not allowed to be modeled.

$$VR_{max} = CFMFPP \times Per \times OF_{max} + A_{flow}$$

$$VR_{min} = CFMFPP \times Per \times OF_{min} + A_{flow}$$

Quiz #17

A 21,000 ft² office building is modeling as-designed HVAC systems for TEDI compliance. The design specifies demand-controlled ventilation (DCV) for the office zones, when determining the VR_{max} and VR_{min} values to model what should be the value of Per in the equation below (Per = occupant density)

- A. 179 sf/person
- B. 0.0056 people/sf = 1/179
- C. As-designed value.
- D. DCV is not allowed to be modeled.

$$VR_{max} = CFMFPP \times Per \times OF_{max} + A_{flow}$$

$$VR_{min} = CFMFPP \times Per \times OF_{min} + A_{flow}$$

Table 6: Standardized Assumptions for Office, Fire Station, Library, Police Station, Post Office, Town Hall, and Other Building Types <= 75,000-sf

Thermal Block Type	Schedule Index (Note 1)	Misc. Loads*	Lighting Power	Ventilation Rate	Occupant Density	Occupant Heat Gain	
		W/sf	W/sf	CFM/sf	sf/Person	Btu/h-person	
						Sensible	Latent
Office, Fire Station, Library, Police Station, Post Office, Town Hall, and Other	↓	0.63	0.64	0.18	179	250	160

* Use a sensible fraction of 1.0 and a latent fraction of 0.0 for all thermal blocks.

Table 6: Standardized Assumptions for Office, Fire Station, Library, Police Station, Post Office, Town Hall, and Other Building Types <= 75,000-sf

Thermal Block Type	Schedule Index (Note 1)	Misc. Loads*	Lighting Power	Ventilation Rate	Occupant Density	Occupant Heat Gain	
		W/sf	W/sf	CFM/sf	sf/Person	Btu/h-person	
						Sensible	Latent
Office, Fire Station, Library, Police Station, Post Office, Town Hall, and Other	↓	0.63	0.64	0.18	179	250	160

* Use a sensible fraction of 1.0 and a latent fraction of 0.0 for all thermal blocks.

HVAC

Other Modeling Requirements

Piping and ductwork losses shall not be modeled.



Special Cases

Core and Shell and Initial Tenant Fit-Out

- For projects in which systems and components that must be modeled as designed following the guidelines have not yet been designed, those yet-to-be-designed features shall be modeled to comply with but not exceed the requirements of the most current version of 225 CMR 23: Massachusetts Commercial Stretch Energy Code.
- Core and shell buildings where the details of the building occupancy is not known shall be categorized as an office building.
- For initial tenant fit-out projects, existing unmodified systems and components shall be modeled as-built. Section C401.2 does not apply to subsequent tenant fit-out projects. Tenant fit-outs after the initial tenant fit-out shall be treated as alterations or change of use as appropriate.

Special Cases Additions

Following C502.1, large additions which are either more than 100% of the size of the existing building or equal to or greater than 20,000-sf require conformance to C401.2. If the addition use type is office, dormitory, fire station, library, school, police station, post office, or town hall, the addition must show compliance with the Targeted Performance Compliance (C401.2 Part 2). In this scenario, the existing building shall be excluded from the model so that only the addition is modeled. Surfaces separating the addition from existing building shall be modeled as adiabatic.

C502.1 *Revise Section C502.1 as follows:*

Add the following first sentence "Additions to an existing building where the addition is up to 100% of the size of the existing building and less than 20,000-sf shall comply with Sections C401.3, C402 through C406, and Section C408. Additions which exceed either of these limits shall comply with the applicable pathway for new construction in C401.2."

Special Cases Core and Shell Example

Question: A core and shell project has a complete envelope design, but interior partitions and the HVAC design will be completed by a future tenant. How should thermal zoning be determined? Should energy recovery be modeled?

Special Cases

Core and Shell Example

Question: A core and shell project has a complete envelope design, but interior partitions and HVAC design will be completed by future tenant. How should thermal zoning be determined? Should energy recovery be modeled?

Answer: Thermal blocks must be modeled following Section 8, Simplified Thermal Block approach. Since the building use type is unknown, office occupancy must be assumed. Energy recovery must be modeled as required in Section C403.7.4 for any of the modeled HVAC systems.

Special Cases

Tenant Fit-Out Example

Question: A core and shell project with a complete envelope design was completed under a separate permit application during this code cycle. The current project is an initial tenant fit-out that includes the design of interior partitions and HVAC systems. How should the building envelope be modeled?

Special Cases

Tenant Fit-Out Example

Question: A core and shell project with a complete envelope design was completed under a separate permit application during this code cycle. The current project is an initial tenant fit-out that includes the design of interior partitions and HVAC systems. How should the building envelope be modeled?

Answer: Building envelope parameters should be modeled following Section 9 and 10 of the guidelines with shape, areas and properties modeled consistently with existing conditions (i.e., as designed and constructed according to the core and shell project.)

Extracting Simulation Results to Determine TEDI



Step 1: Open the eplustbl.html output document generated by E+/Openstudio.

Step 2: Using the Table of Contents hyperlinks to navigate to the Energy Meters section.

Table of Contents

- [Top](#)
- [Annual Building Utility Performance Summary](#)
- [Input Verification and Results Summary](#)
- [Demand End Use Components Summary](#)
- [Source Energy End Use Components Summary](#)
- [Component Sizing Summary](#)
- [Surface Shading Summary](#)
- [Adaptive Comfort Summary](#)
- [Initialization Summary](#)
- [Annual Heat Emissions Summary](#)
- [Climatic Data Summary](#)
- [Envelope Summary](#)
- [Shading Summary](#)
- [Lighting Summary](#)
- [Equipment Summary](#)
- [HVAC Sizing Summary](#)
- [Coil Sizing Details](#)
- [System Summary](#)
- [Outdoor Air Summary](#)
- [Object Count Summary](#)
- [Energy Meters](#)
- [Sensible Heat Gain Summary](#)
- [Standard 62.1 Summary](#)
- [LEED Summary](#)

Step 3: Scroll down to the “Annual and Peak Values – Other” table.

Annual and Peak Values - Other					
	Annual Value [kBtu]	Minimum Value [Btu/h]	Timestamp of Minimum (TIMESTAMP)	Maximum Value [Btu/h]	Timestamp of Maximum (TIMESTAMP)
EnergyTransfer:Facility	2548892.60	0.00	17-JAN-00:10	1489813.35	10-JUL-11:30
EnergyTransfer:Building	830472.04	0.00	04-JAN-22:10	530951.45	10-JUL-15:30
EnergyTransfer:Zone:CORE_BOTTOM ZN	282645.50	0.00	01-JAN-00:10	143790.80	24-JUL-07:20
Heating Energy Transfer	38940.71	0.00	04-JAN-22:10	340743.38	02-JAN-05:10
Heating Energy Transfer:Zone:CORE_BOTTOM ZN	14.68	0.00	01-JAN-00:10	16794.57	02-JAN-07:10
General Heating Energy Transfer	38940.71	0.00	04-JAN-22:10	340743.38	02-JAN-05:10

Step 4: The CoolingCoils:EnergyTransfer, HeatingCoils:EnergyTransfer, and, if applicable, the Baseboard:EnergyTransfer rows are the modeled total cooling and heating loads to use to calculate TEDI. If the html report was generated in imperial units, then these numbers will be in units of kBtu. Divide each by modeled floor area to arrive at the modeled cooling and heating TEDI values.

CoolingCoils:EnergyTransfer	968493.29
HeatingCoils:EnergyTransfer	85068.42

EnergyTransfer:HVAC	3455815.20
Baseboard:EnergyTransfer	70452.91

Extracting Simulation Results to Determine TEDI eQuest

Step 1: After running the simulation to Tool → View Simulation Output...

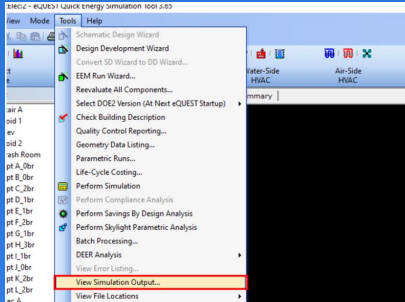

Step 2: Open the output for the simulation.

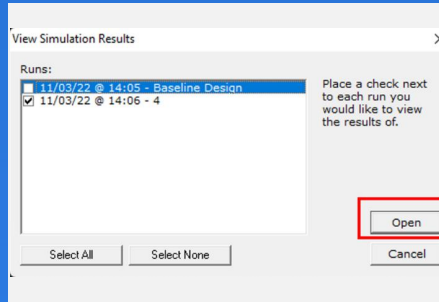

Step 3: Navigate to the SS-D report.

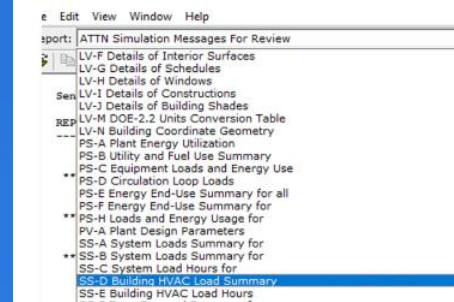

Step 4: Find the heating and cooling loads at the locations shown below in the SS-D report. Multiply each number by 1,000 to convert to kBtu and then divide each by the modeled floor area to arrive at the modeled cooling and heating TEDI values.

REPORT: SS-D Building HVAC Load Summary WEATHER FILE: EPW Boston Logan.Dat

MONTH	COOLING				HEATING				ELECTRICAL					
	COOLING ENERGY OF MAX (MBTU)	TIME OF MAX (HR)	COOLING ENERGY OF MIN (MBTU)	MAXIMUM COOLING LOAD (MBTU)	HEATING ENERGY OF MAX (MBTU)	TIME OF MAX (HR)	HEATING ENERGY OF MIN (MBTU)	MAXIMUM HEATING LOAD (MBTU)	ELECTRICAL ENERGY (KWH)	MAXIMUM ELECTRICAL LOAD (KVA)				
JAN	0.28204	14	14	47.3	38.7	114.240	-12.497	29	0	13.7	13.7	-3203.475	45039	104.137
FEB	10.74594	14	14	38.7	33.7	187.800	-16.175	9	0	14.7	14.7	-1064.401	39412	100.958
MAR	30.84878	27	14	37.7	41.7	240.000	-101.774	14	0	20.7	20.7	-1248.765	59512	84.943
APR	54.42045	15	10	42.7	44.7	453.741	-14.437	9	0	14.7	14.7	-1248.962	37126	94.205
MAY	107.70193	11	10	76.7	53.7	551.573	-2.343	29	0	44.7	42.7	-13.430	34651	105.434
JUN	171.28658	11	10	84.7	71.7	680.343	-0.703	14	0	54.7	52.7	-1.748	42082	110.414
JUL	217.24858	11	10	89.7	73.7	697.284	-0.301	1	2	74.7	71.7	-0.785	45726	113.710
AUG	204.34070	10	10	86.7	72.7	676.035	-0.102	1	2	71.7	62.7	-0.204	44855	111.483
SEP	140.12107	4	10	62.7	79.7	505.544	-0.103	11	0	51.7	42.7	-5.844	36822	110.477
OCT	47.28214	2	10	47.7	52.7	419.744	-2.457	10	0	42.7	37.7	-14.488	37464	85.833
NOV	23.90248	0	14	14.7	43.7	322.117	-13.440	20	0	30.7	28.7	-166.033	36112	82.923
DEC	10.30148	0	14	14.7	43.7	212.631	-16.534	31	0	20.7	24.7	-1222.003	35857	89.234
TOTAL	1148.398						-224.713						487074	
MAX						697.284						-3203.475		113.414

Extracting Simulation Results to Determine TEDI IESVE

Please visit the IESVE [frequently asked questions \(FAQ\) page](#) for instructions for determining heating and cooling *TEDIs* from the IESVE energy model. The instructions on the web page are for generating the heating *TEDI*, to generate the cooling *TEDI* just replace “heating” with “cooling” for both cases of the variables referenced on the FAQs page. Please use the definition in Section 1 for *modeled floor area* for determining the floor area that needs to be manually entered per the instructions on the FAQ page.

If the *TEDIs* generated by IESVE following the instructions on the web page are in units of kWh/m²/yr they will need to be converted to units of kBtu/ft²/yr by multiplying by 0.317.

Documentation Requirements (C407.1.2)



- Completed COMcheck™ Envelope, Lighting and Mechanical Compliance Certificates, and a Plan Review Inspection Checklist (C103.2.2).
- Simulation reports:
 - eQUEST: <project name>.SIM file with the complete set of simulation reports.
 - Energy Plus / Open Studio: Complete set of simulation reports in the HTML format. See Annex A for the report generation instructions.
 - IESVE: Room Loads Report, Zone Loads Report, Space Loads & Ventilation Report, System Loads Report, Energy Model Output Report, Unmet Hours Report, Detailed Simulation Report
- Calculation of the average ventilation rate similar to what is required by Section C103.2 #16
- The items described in ANSI/ASHRAE/IESNA 90.1-2019 Appendix G Section G1.3.2 Parts b, g, h, i, j, k, l, n, o, and q, and Section G1.3.3.
- TEDI Compliance Tool – spreadsheet-based tool with checklist from guidelines, automated QC checks, and compliance outcome calculation.

How to Achieve Low Heating & Cooling TEDI?

- Achieving low heating and cooling TEDIs requires careful attention to envelope performance including insulation levels, orientation, thermal bridging, solar gains, and tightness, and the ventilation system design.
- Solar gains can be addressed with attention to fenestration area and location, solar heat gain coefficient, and external shading.
- Lighting, occupancy, and miscellaneous equipment modeling inputs are prescribed (fixed) and are independent of design. These impact internal heat gains, which affect heating and cooling TEDI. However, these cannot be adjusted as a strategy to meet TEDI requirements.

Relative Performance Path

Topics Covered

- Overview
- Approved simulation tools
- Compliance calculations
- Key differences between MA Stretch 2023 and ASHRAE 90.1 2019 Appendix G
- Schedules
- Reporting requirements

Modeling requirements of the following systems:

- Envelope
- Interior & exterior lighting
- Process and plug loads
- HVAC
- SWH
- Special cases

Overview

- Based on 90.1 2019 Appendix G Performance Rating Method with Massachusetts amendments
- Establishes compliance based on the relative energy use of two models - the proposed design model and the baseline design model
 - The proposed design model must reflect design documents.
 - Baseline model reflects efficiency levels that are approximately aligned with requirements in 90.1 2004
- Requirements are detailed in 2023 Technical Guidance Massachusetts Stretch Energy Codes Attachment B

General Concept of Performance-Based Compliance with 90.1

- Allow projects to not meet some of the prescriptive requirements and make up for the associated energy penalty by exceeding minimum requirements in other areas
- Configuration of both models is prescribed in ASHRAE Standard 90.1
- Energy use of both models is calculated using the same simulation tool and weather file

Proposed Design Based on Design Documents



Simulation Tool

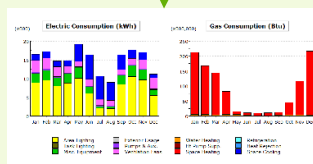

Baseline Design Compliant with ~90.1 2004

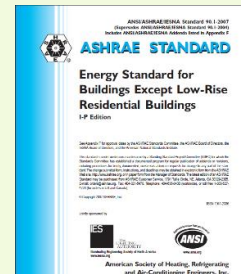

Simulation Tool

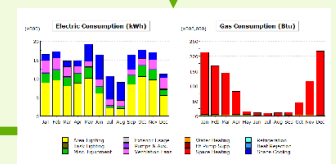

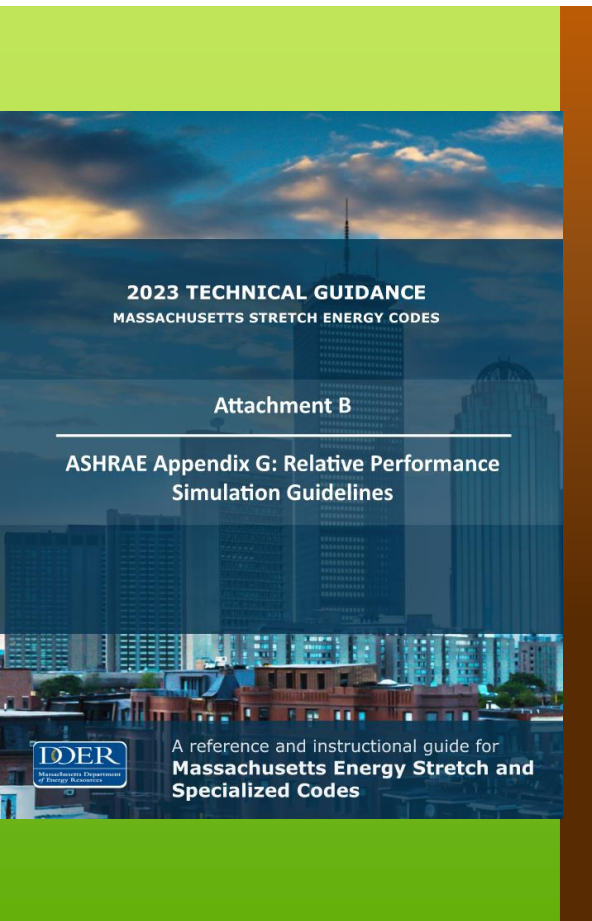

MA Stretch Code 2023 Guidelines Purpose

Improve the accuracy and technical integrity of building energy models used to establish compliance with Section C407.2 Relative Performance by meeting the following objectives:

- Clarify areas where the Relative Performance Path deviates from ANSI/ASHRAE/IESNA Standard 90.1 2019 (90.1) Appendix G PRM due to MA Stretch Code amendments
- Provide requirements for areas that are either not directly addressed by the PRM or are ambiguous.
- Explain PRM rules that are often misapplied or misinterpreted.
- Provide examples to illustrate the above.

The Simulation Guidelines are not a standalone document and must be used in conjunction with the modeling requirements in ASHRAE 90.1 2019 Appendix G and MA Stretch Code 202

MA Stretch Code 2023 Guidelines Location

mass.gov/info-details/stretch-energy-code-development-2022#final-guideline-

Web Tools Programs Equipment/Specs Admin Articles Maps+/Wea Tech & Software Recipes Development Technical Gu

Final Guideline

In September of 2023, DOER released a series of final Technical Guidance documents designed to inform and assist users in implementing the new Stretch and Specialized energy codes. Guidance documents include:

- [Final Stretch and Specialized Code Guidelines](#), including: [Attachment A](#) (Envelope Performance and Thermal Bridge Derating), [Attachment B](#) (ASHRAE Appendix G Relative Performance Simulation Guidelines), [Attachment C](#) (Targeted Performance Simulation Guidelines), [Schedule and Loads Supplement](#), and [weather file](#).
- [Stretch Energy Code Study Support](#)
- [Models conforming to TEDI Requirements](#)

[Link to the MA Stretch Code 2023 Guidelines](#)

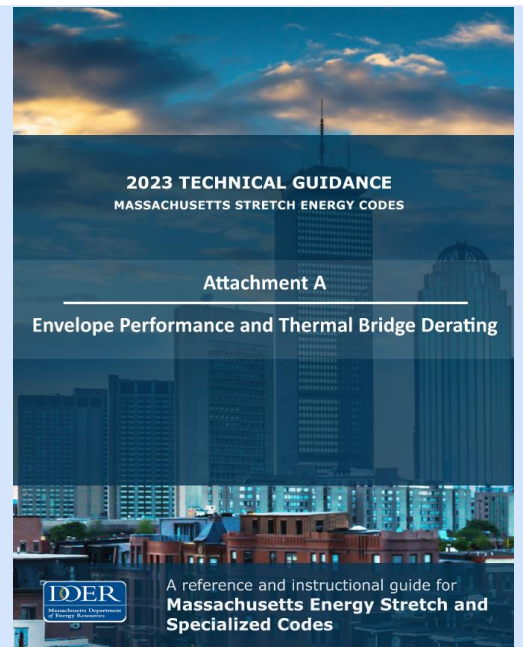

Approved Simulation Tools

- eQUEST, EnergyPlus, IESVE and OpenStudio are preapproved
- Other software tools may be approved by Massachusetts Department of Energy Resources (DOER) on a case-by-case basis, provided that the tool meets requirements of ASHRAE 90.1 2022 Section G2.2.
- If an approved simulation tool used on a project does not have the capability to model a specified system or component specified for the proposed design, supplemental calculations may be used. Such calculations must be documented as required in Section G2.5 and are subject to AHJ approval.

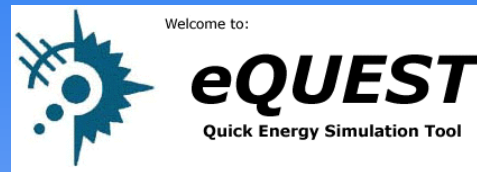

Software Requirements (G2.2)



G2.2.1 The simulation program shall be approved by the rating authority and shall, at a minimum, have the ability to explicitly model all of the following:

- 8,760 hours per year;
- Hourly variations in occupancy, lighting power, miscellaneous equipment power, thermostat setpoints, and HVAC system operation, defined separately for each day of the week and holidays;
- Thermal mass effects;
- Ten or more thermal zones;
- Part-load performance curves for mechanical equipment;
- Capacity and efficiency correction curves for mechanical heating and cooling equipment;
- Air-side economizers with integrated control;
- Baseline building design characteristics specified in G3.

G2.2.3 The simulation program shall be capable of performing design load calculations to determine required HVAC equipment capacities and air and water flow rates in accordance with generally accepted engineering standards and handbooks (for example, ASHRAE Handbook—Fundamentals) for both the proposed design and baseline building design.

Exceptional Calculations (G2.5)

If an approved simulation tool used on a project does not have the capability to calculate energy usage/savings for a design feature allowed by 90.1 PRM, supplemental calculations may be used.

Such calculations, must be documented following requirements of Section G2.5 summarized below, and are subject to AHJ approval:

- Step-by-step documentation of the Exceptional Calculation Method performed detailed enough to reproduce the results
- Copies of all spreadsheets used to perform the calculations
- A sensitivity analysis of energy consumption when each of the input parameters is varied from half to double the assumed value
- The calculations shall be performed on an hourly time step basis
- The Performance Energy Use calculated with and without the Exceptional Calculation Method
- The total savings documented using the Exceptional Calculation Methods cannot account for more than half of the difference between the baseline building performance and the proposed building performance. This cap is incorporated in the MA Stretch Companion Tool.

Proposed Design Model

- Must reflect buildings systems, components and controls specified in the construction documents
- The modeled operating conditions and schedules must reflect the expected operation of the building or typical for the given building use type
- The following systems must be excluded from the proposed design model (MA Stretch amendments to 90.1 G2.4.1):
 - Energy used to recharge vehicles that are used for on-road and off-site transportation purposes, or energy losses from use of behind-the-meter energy storage
 - On-site renewable energy systems

Baseline Design Model

The same building use type, programming, envelope shape, HVAC zoning and operating schedules (with some exceptions) as the proposed design model.

Most systems and components regulated by energy code (envelope constructions, fenestration area, HVAC system type and controls, SWH system type and lighting power and controls) are prescribed in 90.1 Appendix G, are independent from the specified systems and are modeled at efficiency levels approximately aligned with 90.1 2004.

Parameters that are not explicitly defined in 90.1 PRM must be modeled the same as in the proposed design.

The end uses that are not included in the proposed design must not be modeled in the baseline. For example, if the project includes a parking lot for which no exterior lighting is specified, the parking lot lighting power allowance cannot be modeled in the baseline.

Baseline energy use is calculated as an average of four alternative orientations of the baseline design model except when exposure is dictated by building site or when fenestration area on different exposures differ by less than 5%.

Compliance Calculations Performance Energy Index

- Performance of the proposed design relative to the baseline is expressed as Performance Energy Index (PEI)

$$PEI = \frac{\text{Proposed Building Site Energy}}{\text{Baseline Building Site Energy}}$$

- Project meets code if the PEI is less than or equal to the Performance Energy Index Target (PEI_T)

$$PEI \leq PEI_T$$

Performance Energy Index Target

$$PEI_T = \frac{(BBUE + (BPF \times BBRE))}{BBP}$$

BBUE = Baseline Building
Unregulated Site Energy

BBRE = Baseline Building Regulated
Site Energy

BBP = Baseline Building Performance; $BBP = BBUEC + BBREC$

BPF = Building Performance Factor

Unregulated Energy

$$PEI_T = \frac{(BBUE + (BPF \times BBRE))}{BBP}$$

- Energy use of systems and components that have no requirements in 90.1 Sections 5-10 are considered **UNREGULATED**.
- As a general rule, **unregulated components must be modeled the same in the baseline and proposed design.**



Regulated Energy

$$PEI_T = \frac{(BBUE + (BPF \times BBRE))}{BBP}$$

- Energy use of systems and components with requirements prescribed in 90.1 Sections 5-10 are considered regulated. Envelope of conditioned spaces, lighting, HVAC are examples of **REGULATED** systems.
- In the **baseline** model, the regulated systems are modeled at the **efficiency levels prescribed in Appendix G** that are generally consistent with the requirements of 90.1 2004.
- In the proposed model, regulated loads must match the design documents.



Building Performance Factor



$$PEI_T = \frac{(BBUE + (BPF \times BBRE))}{BBP}$$

- Quantifies stringency of MA Stretch Code relative to 90.1 2004 which is used as the basis for the baseline model
- Determined using DOE/PNNL Prototype Models
 - Representative of the US building stock
 - Versions of these models are created for each edition of Standard 90.1 starting with 2004
 - BPF for each building type and climate zone is calculated as the ratio of the regulated energy cost of the prototype model configured to minimally comply with 90.1 2019 versus the prototype configured to minimally comply with 90.1 2004
 - The results for similar building types (e.g., different size of office buildings) are averaged

Building Type	Prototype Building
Office	Small Office
	Medium Office
	Large Office
Retail	Stand-Alone Retail
	Strip Mall
School	Primary School
	Secondary School
Healthcare/Hospital	Outpatient Health Care
	Hospital
Lodging/Hotel	Small Hotel
	Large Hotel
Warehouse	Warehouse
Restaurant	Fast Food Restaurant
	Sit-Down Restaurant
Apartment (Multi-family)	Mid-Rise Apartment
	High-Rise Apartment

MA Stretch Building Performance Factor



- The MA Stretch Building Performance Factors are based on ASHRAE 90.1-2022 Informative Appendix I, Table 13-1, which provides the BPFs for jurisdictions adopting ASHRAE 90.1 2022 Appendix G using site energy metric.
- The 90.1 Appendix I BPFs have been further reduced by 10%, resulting in 10% increase in stringency relative to 2022 requirements
- Building occupancies for which TEDI path is required are excluded from the BPF table

Table 4.2.1.1 Building Performance Factor (BPF)

Building Area Type	Climate Zone 5A
Health Care/Hospital	0.59
Hotel/Motel	0.57
Restaurant	0.62
Retail	0.47
Warehouse	0.41
All Others	0.51

Quiz #18

A project was modeled following the Relative Performance path. The modeling results are shown below:

Site energy use intensity of the baseline building design is 50 kBtu/ft²

Site energy use intensity of the proposed design is 25 kBtu/ft²

Performance Energy Index Target is 0.55
Performance Energy Index is $25 \div 50 = 0.5$

The proposed design has a 50% lower site EUI than the baseline. Does this mean that the project is $25 \div 50 \times 100 = 50\%$ improved over code?

- A. Yes
- B. No

Quiz #18

A project was modeled following the Relative Performance path. The modeling results are shown below:

Site energy use intensity of the baseline building design is 50 kBtu/ft²

Site energy use intensity of the proposed design is 25 kBtu/ft²

Performance Energy Index Target is 0.55

Performance Energy Index is $25 \div 50 = 0.5$

The proposed design has a 50% lower site EUI than the baseline. Does this mean that the project is $25 \div 50 \times 100 = 50\%$ improved over code?

A. Yes

B. No! The baseline design represents a building that is approximately as efficient as was necessary to comply with 90.1 2004 and the proposed design is 50% better than this inefficient baseline building.

Quiz #19

Continuing the previous poll, is there a way to estimate improvement of the proposed design beyond MA Stretch code without developing an additional model of a minimally code compliant design? If so, what would be the percent savings?

Reminder:

Site energy use intensity of the baseline building design is 50 kBtu/ft²

Site energy use intensity of the proposed design is 25 kBtu/ft²

Performance Energy Index Target is 0.55

Performance Energy Index is $25 \div 50 = 0.5$

A. Yes

B. No

Quiz #19

Continuing the previous poll, is there a way to estimate improvement of the proposed design beyond MA Stretch code without developing an additional model of a minimally code compliant design? If so, what would be the percent savings?

Reminder:

Site energy use intensity of the baseline building design is 50 kBtu/ft²

Site energy use intensity of the proposed design is 25 kBtu/ft²

Performance Energy Index Target is 0.55

Performance Energy Index is $25 \div 50 = 0.5$

A. Yes

$$\text{Improvement beyond code} = \frac{(0.55 - 0.5)}{0.55} = 9.1\%$$

A. No

Key Differences Between 90.1 2019 Appendix G and MA Stretch Code

	90.1 2019 Appendix G	C407.2 Relative Performance
Compliance Metric	energy cost	site energy
Contribution of renewable energy toward compliance allowed?	Yes, up to 5% of baseline energy cost	No
Additional Efficiency Requirements (Section C406) apply?	No	Yes, but improvement in performance due to C406 measures can also contribute toward improving Performance Energy Index.
Additional envelope requirements	90.1 mandatory provisions	90.1 mandatory provisions; Must meet C402.1.5 (component performance alternative) Modeled vertical envelope must be derated to account for thermal bridging
Additional lighting requirements	90.1 mandatory provisions; must not be worse than baseline lighting power (90.1 2004)	90.1 mandatory provisions, MA Stretch C405 electrical power and lighting system requirements.
Additional HVAC requirements	90.1 mandatory provisions	90.1 mandatory provisions, prescriptive requirements for economizer and ventilation and exhaust systems (including exhaust air energy recovery)
Additional SWH requirements	90.1 mandatory provisions	90.1 mandatory provisions
Stringency	As prescribed in 90.1 2019	10% more stringent than 90.1 2022 on site energy bases; achieved by reducing the BPFs by 10%

Key Differences Between 90.1 2019 Appendix G and MA Stretch Code

	90.1 2019 Appendix G	C407.2 Relative Performance
Compliance Metric	energy cost	site energy
Contribution of renewable energy toward compliance allowed?	Yes, up to 5% of baseline energy cost	No
Additional Efficiency Requirements (Section C406) apply?	No	Yes, but improvement in performance due to C406 measures can also contribute toward improving Performance Energy Index.
Additional envelope requirements	90.1 mandatory provisions	90.1 mandatory provisions; Must meet C402.1.5 (component performance alternative) Modeled vertical envelope must be derated to account for thermal bridging
Additional lighting requirements	90.1 mandatory provisions; must not be worse than baseline lighting power (90.1 2004)	90.1 mandatory provisions, MA Stretch C405 electrical power and lighting system requirements.
Additional HVAC requirements	90.1 mandatory provisions	90.1 mandatory provisions, prescriptive requirements for economizer and ventilation and exhaust systems (including exhaust air energy recovery)
Additional SWH requirements	90.1 mandatory provisions	90.1 mandatory provisions
Stringency	As prescribed in 90.1 2019	10% more stringent than 90.1 2022 on site energy bases; achieved by reducing the BPFs by 10%

90.1 Appendix G Table G3.1 #4

Schedules may be allowed to differ between proposed design and baseline building design when necessary to model nonstandard efficiency measures, provided that the revised schedules have been approved by the rating authority.

Measures that may warrant use of different schedules include but are not limited to automatic lighting controls, automatic natural ventilation controls, automatic demand control ventilation controls, and automatic controls that reduce service water-heating loads. In no case shall schedules differ where the controls are manual (e.g., manual operation of light switches or manual operation of windows).

Operating and Other Schedules

Sources of Typical Schedules

Standardized schedules prescribed for Section C407.1 (TEDI) may be used.

For residential occupancies, schedules prescribed in the ENERGY STAR Multifamily New Construction Program Simulation Guidelines must be used.

Other sources of typical schedules:

90.1 Section C3.5.5.3 Schedules and Internal Loads (Building Envelope Trade-Off)

ASHRAE 90.1-2019 User Manual (for purchase only).

Comnet Appendix C Schedules



Envelope

90.1 Mandatory Requirements

- Building envelope insulation must be labeled with the rated R-value and installed as recommended by manufacturer to achieve the rated R-value and de-rated to account for thermal bridging as described in 90.1 Appendix A (Section 5.4.1).
- Fenestration and doors must be rated following the allowed testing procedures (Section 5.4.2).
- The building envelope must have a continuous air barrier. The compliance may be demonstrated by either whole building pressurization testing or using approved materials and assemblies (Section 5.4.3.1)
- Loading docks must have weatherseals to restrict infiltration when vehicles are parked in the doorways (Section 5.4.3.2).
- Building entrances that separate conditioned space from the exterior must have enclosed vestibule, with all doors opening into and out of the vestibule equipped with self-closing devices (Section 5.4.3.3).

Other MA Stretch 2023 Mandatory Requirements

Code Requirement for Building Envelope

C401.3 Thermal envelope certification (Unchanged from IECC)

Must post thermal envelope certificate with the key performance characteristics of the opaque envelope and fenestration and air leakage testing results.

C402.1.5 Component Performance Alternative

- Allows performance trade-offs within vertical assemblies by prescribing limits on the area-weighted U-factor for above grade wall assemblies and whole assembly U-factors for vision glass glazed wall systems. The maximum allowed U-factors in either Section C402.1.5.1 or C402.1.5.2 depends on the percentage of the exterior wall taken up by glazed wall systems;
- Fenestration shall meet the applicable SHGC requirements of Section C402.4.3.

C402.2.8 Requirement for combustion fireplaces

C402.3 Rooftop solar readiness

C402.4.6 Fenestration Documentation

Allowed methods for determining fenestration performance.

C402.5 Air Leakage

Air barrier design and testing requirements; maximum allowed air leakage rates.

C402.7 Derating and Thermal Bridges

Methodology that must be used to account for thermal bridging in exterior walls

(Reminder from 4-Hour Training)

Floor Plan Details That Must Be Modeled

HVAC zones must be modeled individually or combined into a single thermal block if all of the following conditions are met:

- The space use classification is the same throughout the thermal block
- All HVAC zones in the thermal block that are adjacent to glazed exterior walls face the same orientation or their orientations vary by less than 45 degrees.
- All of the zones are served by the same HVAC system or by the same kind of HVAC system.

Special rules for residential spaces

- At least one thermal block per dwelling unit, except units facing the same orientations may be combined into one thermal block.
- Corner units and units with roof or floor loads may only be combined with similar units.

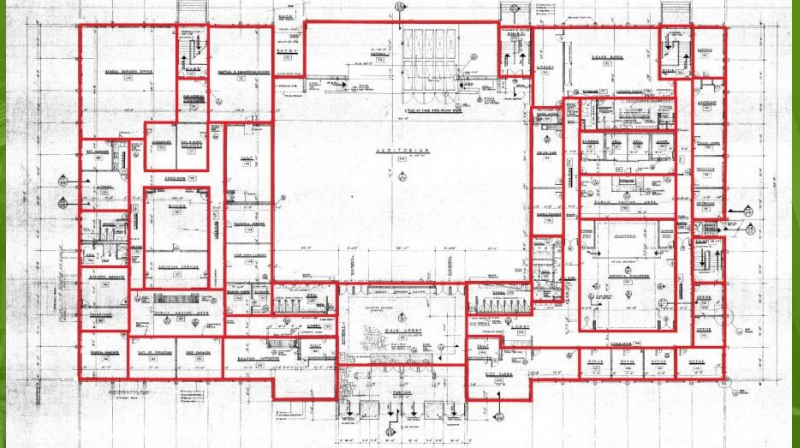

These rules were covered in the TEDI section of this training

Unenclosed Spaces

Areas that are not classified as enclosed spaces per 90.1 definition including ventilated attics, ventilated crawlspaces and parking garages that are mechanically or naturally ventilated may be either explicitly modeled or excluded from the model.

Whichever approach is selected for each such space, it must be applied to that space in both the baseline and proposed design models. If excluded, the associated surfaces that are not part of the building envelope must also be excluded from the model, and surfaces that are part of the building envelope must be modeled as having direct exterior exposure.

Unenclosed Spaces Example

Question: A building has an unconditioned, mechanically ventilated parking garage on the first floor and hotel occupancy on floors 2-6. How should the parking garage be modeled?

Answer: A parking garage may be modeled explicitly as shown on construction documents or omitted from the model. If omitted, the floor of the hotel above the parking garage must be modeled as adjacent to exterior. The selected modeling approach must be used for both the baseline and proposed design. Irrespective of the selected approach, parking garage loads such as lighting and ventilation must be modeled.



WELCOME
WE ARE
WOMEN
PLEASE COME IN

Envelope: Proposed Design

Envelope Properties

Modeled envelope properties must reflect materials and constructions included in design documents.

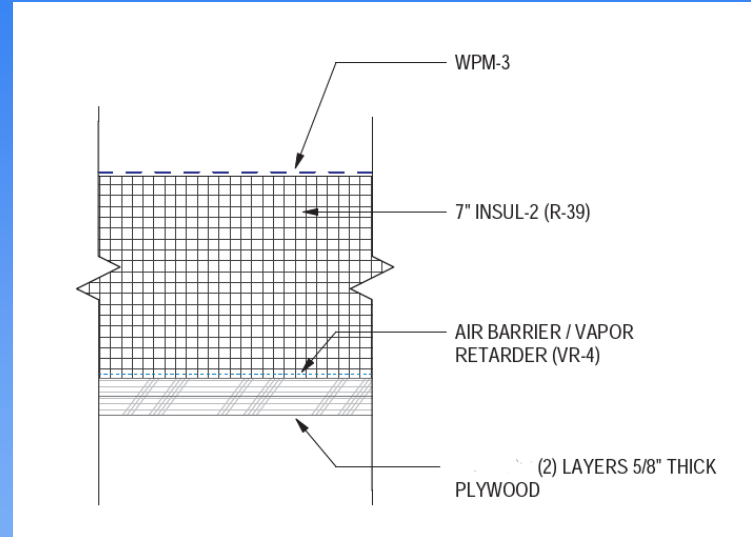

Relative Performance – Proposed

Allowed Envelope Simplifications (Table G3.1 #5)



- Uninsulated assemblies (projecting balconies, perimeter edges of intermediate floor slabs, concrete floor beams over parking garages, roof parapet, etc.) may be modeled as surface bands, as illustrated in the Figure.
- Assemblies accounting for less than 5% of the total area of this surface type (e.g., exterior wall) may be aggregated with the adjacent surface, and the overall U-factor of the aggregated assembly determined as area-weighted average.
- Exterior surfaces whose azimuth, orientation and tilt differ by less than 45 degrees and are otherwise the same may be modeled as a single surface.

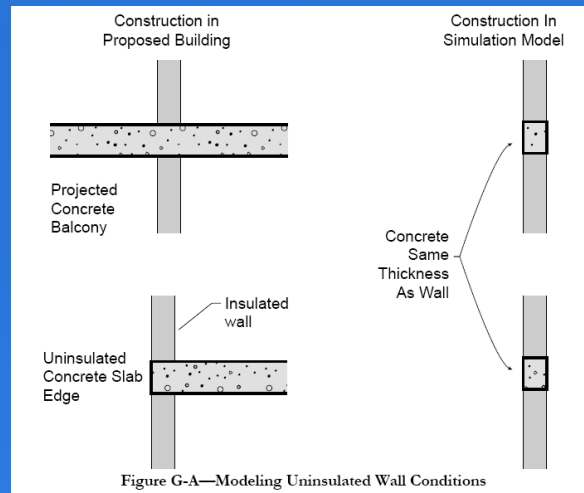
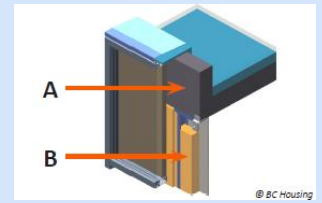
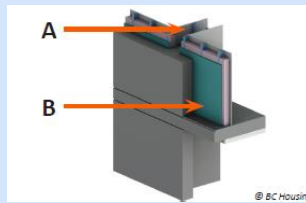
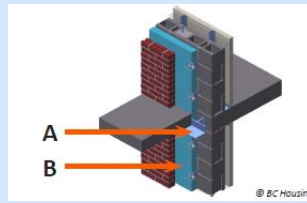
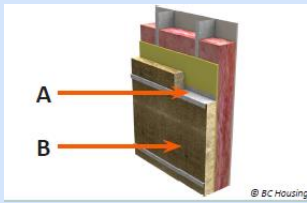
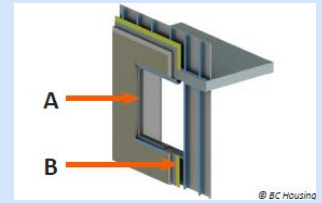
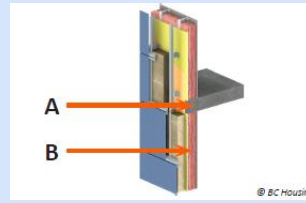
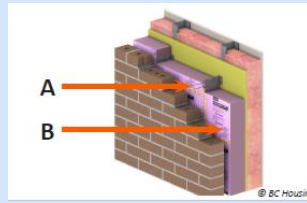
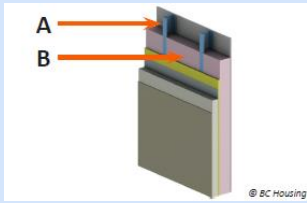

Figure G C. Simplifying Building Geometry for Energy Simulation
Corresponding section: Building Envelope (Table G3.1, No. 5)—Different Tilt or Azimuth

Relative Performance – Proposed

Thermal Bridging



Modeled thermal transmittance of wall assemblies must be derated to account for clear field, linear and point thermal bridges as described in C402.7. Any derating method allowed in Section C402.7 may be used.

[Link to MA Stretch 2023 Envelope Performance and Thermal Bridging Guideline](#)

Relative Performance – Proposed

Infiltration (Air Leakage)

- The same infiltration modeling algorithm and schedule must be used for baseline and proposed design models.
- Modeled air leakage must be based on testing as required by Section C402.5.2. The test results must be converted to simulation inputs as prescribed in 90.1 Section G3.1.1.4. Infiltration must be modeled at 100% (i.e. with schedule fraction of 1) during unoccupied hours when HVAC systems are of, and at 25% during occupied hours (i.e. with schedule fraction of 0.25). If simulation tool restricts changes to infiltration schedule, infiltration can be ignored during occupied hours by modeling infiltration schedule fraction of 0 when fans are on.

Relative Performance – Proposed

Penalty for HVAC Envelope Penetrations

When the total area of penetrations from mechanical equipment, including but not limited to through-wall AC sleeves and PTAC/PTHP but excluding ventilation louvers, exceeds 1% of the opaque above-grade wall area, the area of the penetrations must be modeled in the Proposed Design with a default U-factor of 0.5. When mechanical equipment has been tested in accordance with approved testing standards, the mechanical equipment penetration area may be calculated as a separate wall assembly with the U-factor as determined by such test. Insulated covers for the through-wall AC units must not be modeled even when specified.

Relative Performance – Proposed

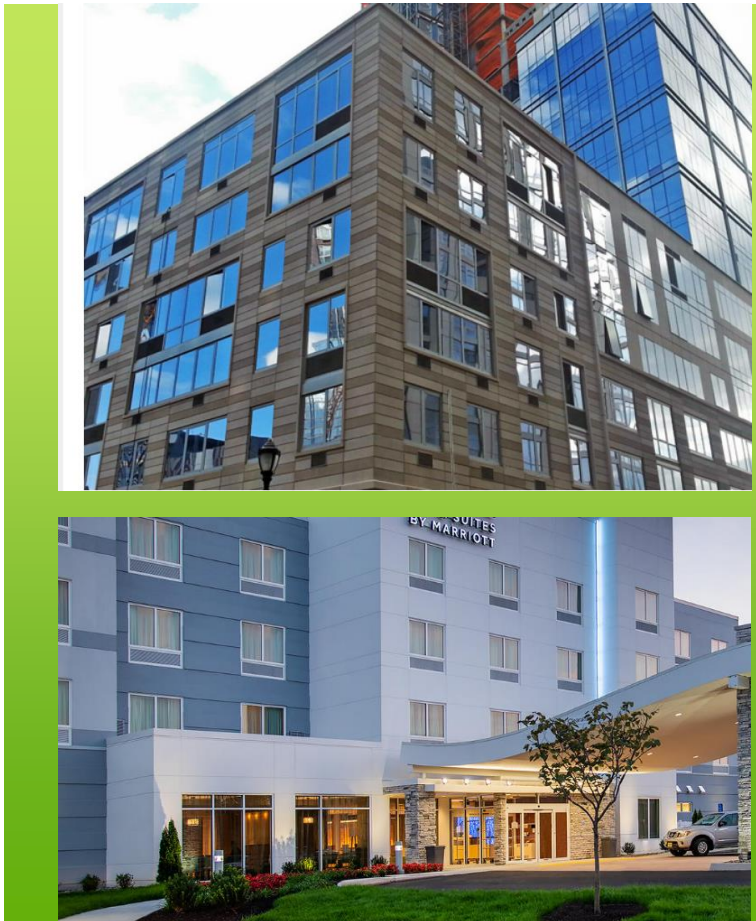

NFRC Rating

 National Fenestration Rating Council® CERTIFIED	World's Best Window Co. Series "2000" Casement Vinyl Clad Wood Frame Double Glazing•Argon Fill•Low E XYZ-X-1-00001-00001	
	ENERGY PERFORMANCE RATINGS	
U-Factor (U.S. / I-P)	Solar Heat Gain Coefficient	
0.35	0.32	
ADDITIONAL PERFORMANCE RATINGS		
Visible Transmittance	Air Leakage (U.S. / I-P)	
0.51	≤0.3	
Condensation Resistance		
51	—	
<small>Manufacturer stipulates that these ratings conform to applicable NFRC procedures for determining whole product performance. NFRC ratings are determined for a fixed set of environmental conditions and a specific product size. NFRC does not recommend any product and does not warrant the suitability of any product for any specific use. Consult manufacturer's literature for other product performance information. www.nfrc.org </small>		

Relative Performance – Proposed

Fenestration Properties

Fenestration must be modeled to reflect whole window assembly U-factors (including framing) and not the center-of-glass U-factor. Acceptable sources for overall fenestration U-factors include the following:

- NFRC rating from the window manufacturer for the entire fenestration unit. (This is usually only available for standard window sizes.)
- LBNL WINDOW software (<http://windows.lbl.gov/software/window/window.html>)
- Modeling the framing and glazing explicitly in the whole building simulation tool used for the project based on known thermal properties and dimensions of the framing and glazing
- ASHRAE Fundamentals 2021, Chapter 15 Table 4.
- If both summer and winter U-factors are available, winter U-factor must be modeled as it reflects the testing conditions of NFRC 100 referenced in 90.1 Section 5.8.2.3.

Envelope: Baseline Design

Opaque and Fenestration Properties

- Same gross area of each exterior envelope component type as in proposed design.
- Thermal properties from Table G 3.4-5 conforming with assemblies detailed in 90.1 Appendix A

Table G3.4-5 Performance Rating Method Building Envelope Requirements for Climate Zone 5 (A,B,C)*

Opaque Elements	Nonresidential Assembly Maximum	Residential Assembly Maximum	Semiheated Assembly Maximum
Roofs			
Insulation entirely above deck	U-0.063	U-0.063	U-0.173
Walls, Above-Grade			
Steel-framed	U-0.084	U-0.064	U-0.124
Wall, Below-Grade			
Below-grade wall	C-1.140	C-1.140	C-1.140
Floors			
Steel-joist	U-0.052	U-0.038	U-0.069
Slab-on-Grade Floors			
Unheated	F-0.730	F-0.730	F-0.730
Opaque Doors			
Swinging	U-0.700	U-0.700	U-0.700
Nonswinging	U-1.450	U-0.500	U-1.450

Applies to exterior envelope of non-residential spaces

Applies to exterior envelope of residential spaces

Applies to semi-exterior envelope

Baseline envelope requirements depend on whether the space is:

- Residential OR non-residential
- Conditioned, semiheated or unconditioned

Exterior building envelope: the elements of a building that separate conditioned spaces from the exterior (90.1 Section 3)

Semiexterior building envelope: the elements of a building that separate conditioned space from unconditioned space or that enclose semiheated spaces through which thermal energy may be transferred to or from the exterior, to or from unconditioned spaces, or to or from conditioned spaces (90.1 Section 3).

Quiz #20

What wall U-value should be modeled in the baseline design model for a wall between an unconditioned, unventilated storage room and a conditioned corridor in a multifamily building?

- A. U-0.064
- B. U-0.124
- C. Same as proposed because it is unregulated.
- D. Need to look at Table 5.5-5 to answer this question.

Table G3.4-5 Performance Rating Method Building Envelope Requirements for Climate Zone 5 (A,B,C)*

Opaque Elements	Nonresidential	Residential	Semiheated
	Assembly Maximum	Assembly Maximum	Assembly Maximum
Roofs			
Insulation entirely above deck	U-0.063	U-0.063	U-0.173
Walls, Above-Grade			
Steel-framed	U-0.084	U-0.064	U-0.124
Wall, Below-Grade			
Below-grade wall	C-1.140	C-1.140	C-1.140
Floors			
Steel-joist	U-0.052	U-0.038	U-0.069
Slab-on-Grade Floors			
Unheated	F-0.730	F-0.730	F-0.730
Opaque Doors			
Swinging	U-0.700	U-0.700	U-0.700
Nonswinging	U-1.450	U-0.500	U-1.450

Quiz #20

What wall U-value should be modeled in the baseline design model for a wall between an unconditioned, unventilated storage room and a conditioned corridor in a multifamily building?

- A. U-0.064
- B. U-0.124
- C. Same as proposed because it is unregulated.
- D. Need to look at Table 5.5-5 to answer this question.

Table G3.4-5 Performance Rating Method Building Envelope Requirements for Climate Zone 5 (A,B,C)*

Opaque Elements	Nonresidential	Residential	Semiheated
	Assembly Maximum	Assembly Maximum	Assembly Maximum
Roofs			
Insulation entirely above deck	U-0.063	U-0.063	U-0.173
Walls, Above-Grade			
Steel-framed	U-0.084	U-0.064	U-0.124
Wall, Below-Grade			
Below-grade wall	C-1.140	C-1.140	C-1.140
Floors			
Steel-joist	U-0.052	U-0.038	U-0.069
Slab-on-Grade Floors			
Unheated	F-0.730	F-0.730	F-0.730
Opaque Doors			
Swinging	U-0.700	U-0.700	U-0.700
Nonswinging	U-1.450	U-0.500	U-1.450

Semiexterior building envelope: the elements of a building that separate conditioned space from unconditioned space or that enclose semiheated spaces through which thermal energy may be transferred to or from the exterior, to or from unconditioned spaces, or to or from conditioned spaces (90.1 Section 3).

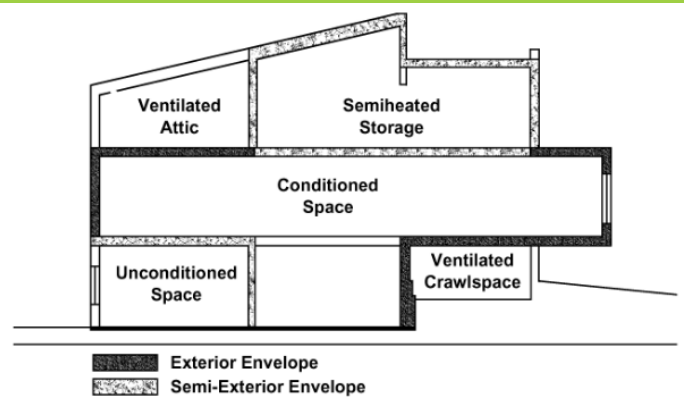

ASHRAE 90.1 Figure 5.5.2 Exterior and semiexterior building envelope

Baseline Vertical Fenestration Area (Table G3.1 #5)

- For other building types, vertical fenestration area is equal that in the *proposed design* or 40% of gross *above-grade wall* area, whichever is smaller.
- Fenestration in the baseline design must be distributed on each face of the building in the same proportions as in the proposed design.
- In mixed use buildings, the rule must be applied to each building area type

Table G3.1.1-1 Baseline Building Vertical Fenestration Percentage of Gross Above-Grade-Wall Area

Building Area Types ^a	Baseline Building Gross Above-Grade-Wall Area
Grocery store	7%
Healthcare (outpatient)	21%
Hospital	27%
Hotel/motel (≤75 rooms)	24%
Hotel/motel (>75 rooms)	34%
Office (≤5000 ft ²)	19%
Office (5000 to 50,000 ft ²)	31%
Office (>50,000 ft ²)	40%
Restaurant (quick service)	34%
Restaurant (full service)	24%
Retail (stand alone)	11%
Retail (strip mall)	20%
School (primary)	22%
School (secondary and university)	22%
Warehouse (nonrefrigerated)	6%
Multifamily	24%

Based on the area of exterior walls of conditioned and semi-heated spaces (exterior and semi-heated envelope)

MA Amendment

- Doors that are more than one-half glass are considered fenestration

Relative Performance – Baseline

Fenestration Area Example



Question: The figure below shows an elevation view of an office building. Which of the walls must be included in the fenestration area calculation?

Figure 5.5.2 Exterior and *semiexterior* building envelope

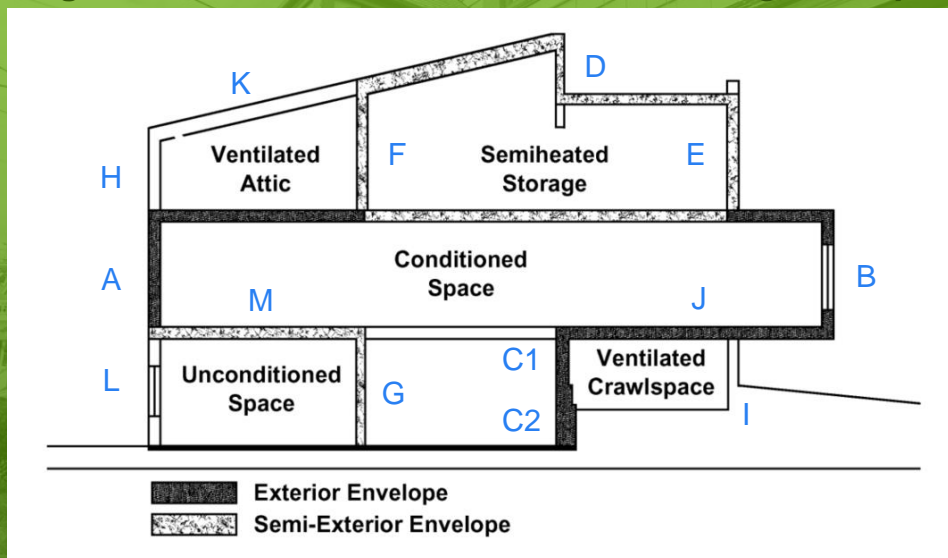

Relative Performance – Baseline

Fenestration Area Example

Answer: Area of walls F, D, E, B, A, C1 and G must be included when calculating baseline fenestration area in accordance with Table G3.1 part 5 item c.

Figure 5.5.2 Exterior and *semi*exterior building envelope

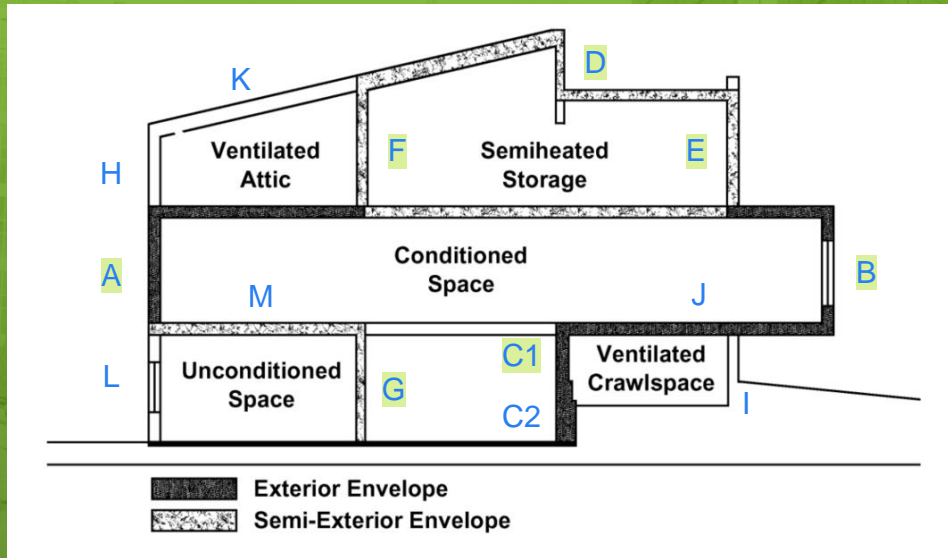

Relative Performance – Baseline

Infiltration (Air Leakage)

The modeled air leakage rate in the baseline design must be modeled based on a leakage rate of 1.0 cfm/ft² of the building thermal envelope at a pressure differential of 0.3" water gauge (75 Pa).

The building thermal envelope area must include the above- and below-grade conditioned and semi-heated walls, ceilings/roofs and floors. Simulation inputs must be determined following 90.1 Section G3.1.1.4 which prescribes conversion factors and procedures for normalizing the infiltration rate by appropriate surface area based on simulation program input requirements.

Relative Performance – Baseline

Interior Lighting

90.1 Mandatory Requirements

Lighting Controls 9.4.1.1, 9.4.1.2 (parking garage) and 9.4.1.3 (special applications)

- Daylighting required for most spaces with windows or skylights
- Occupancy-based controls such as automatic full off / partial off, manual on / partial automatic on, scheduled shut-off, bi-level lighting are required in most space types

Table 9.6.1 Lighting Power Density Allowances Using the Space-by-Space Method and Minimum Control Requirements Using Either Method (Continued)

Common Space Types ¹	LPD, W/ft ²	RCR Threshold	The control functions below shall be implemented in accordance with the descriptions found in the referenced paragraphs within Section 9.4.1.1. For each space type: (1) All RCRs shall be implemented. (2) At least one ADD1 (when present) shall be implemented. (3) At least one ADD2 (when present) shall be implemented.								
			Local Control (See Section 9.4.1.1[d])	Restricted to Manual ON (See Section 9.4.1.1[D])	Restricted to Partial Automatic ON (See Section 9.4.1.1[C])	Bi-level Lighting Control (See Section 9.4.1.1[d])	Automatic Daylight Responsive Controls for Sidelighting (See Section 9.4.1.1[e] ²)	Automatic Daylight Responsive Controls for Toplighting (See Section 9.4.1.1[F])	Automatic Partial OFF (See Section 9.4.1.1[G])	Automatic Full OFF (See Section 9.4.1.1[H])	Scheduled Shutoff (See Section 9.4.1.1[I])
Office											
Enclosed and >250 ft ²	0.93	8	REQ	ADD1	ADD1	REQ	REQ	REQ		REQ	
Enclosed and >250 ft ²	0.93	8	REQ	ADD1	ADD1	REQ	REQ	REQ		ADD2	ADD2
Open plan	0.61	4	REQ	ADD1	ADD1	REQ	REQ	REQ		ADD2	ADD2
Parking Area, Interior	0.14	4	See Section 9.4.1.2								
Pharmacy Area	1.34	6	REQ	ADD1	ADD1	REQ	REQ	REQ		ADD2	ADD2
Restroom											
Facility for the visually impaired (and not used primarily by the staff) ³	0.96	8					REQ	REQ		REQ	
All other restrooms	0.85	8					REQ	REQ		REQ	

Lighting in dwelling units (9.4.3)

At least 75% of the permanently installed lighting fixtures must use lamps with an efficacy of at least 55 lm/W or have a total luminaire efficacy of at least 45 lm/W.

Lighting power must improve over **90.1 2004** prescriptive requirements (G1.2.1b)

Other MA Stretch 2023 Mandatory Requirements (Reminder)

Code Requirement

C405 Electric Power and Lighting Systems

Interior and exterior lighting power and controls; electric metering; transformers; motors; vertical and horizontal transportation systems and equipment; voltage drop; automatic receptacle controls; energy monitoring; provisions for the electric vehicles ready parking spaces.



Interior Lighting: Proposed Design

FROM LIGHTING PLANS

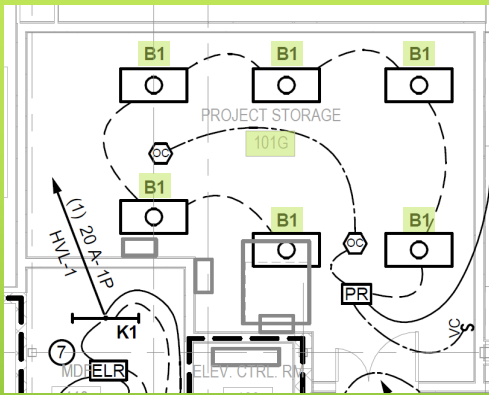

FROM LIGHTING SCHEDULES

B1	PHILIPS LIGHTING OR ACCEPTABLE EQUIVALENT BY:	43.2W LED 4800 DELIVERED LUMENS 3500K 80CRI
----	---	---

LIGHTING CALCULATIONS

Fixture B1 Quantity in Space 101G = 6
 $6 * 43.2 \text{ W} = 259.2 \text{ Watt}$

Relative Performance – Proposed

Proposed Design Lighting Power

General, task and furniture-mounted fixtures must be included in the lighting power calculations except for emergency lighting that is automatically turned off during normal building operation.

For each lighting fixture, all lighting system components shown or provided for on plans must be accounted for including lamps, ballasts, transformers and control devices.

The maximum labeled lighting fixture wattage must be used, which may be different from wattage shown on lighting schedules. Except for incandescent sources, fixture input wattage is not the same as lamp wattage. Input wattage for all discharge sources is determined by the interaction between lamps, ballast, and fixture construction

For track lighting, the modeled wattage must not be less than 30 W/lin ft. See Section 9.1.4 for other rules applicable to track lighting.

Lighting Not Fully Specified

In spaces where lighting is connected via receptacles and not shown on design documents, lighting power used in the simulation must be equal to the lighting power allowance in 90.1 Table 9.6.1 for the appropriate space type or as designed, whichever is greater.

For the dwelling units, lighting power used in the simulation must be equal to 0.60 W/ft² or as designed, whichever is greater.

This provision in Table G3.1 #6 (e), Proposed Building Performance column was added in 90.1 2019 to ensure that spaces where lighting is not specified or only partially specified do not contribute to lighting power savings.

Partially specified lighting is common for dwelling units, hotel/motel guestrooms and dormitory living quarters.

Relative Performance – Proposed

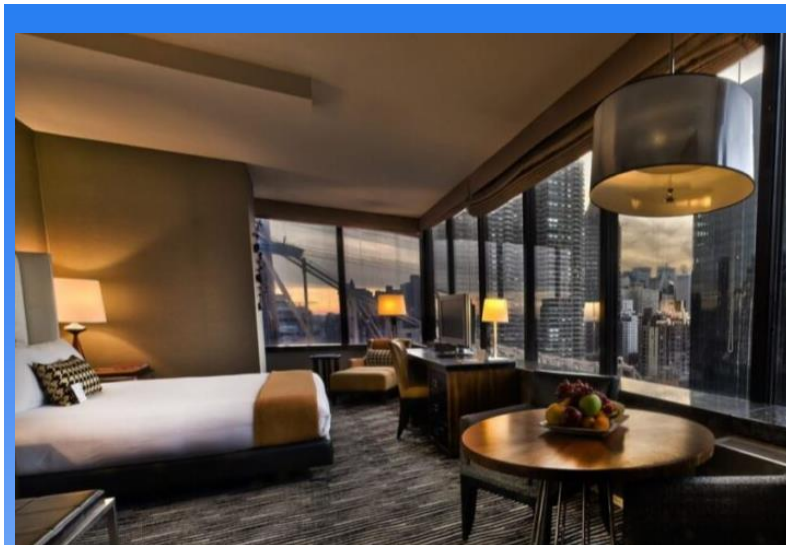

Table 9.6.1 Lighting Power Density Allowances Using the Space-by-Space Method

Common Space Types ¹	LPD Allowances, W/ft ²	RCF Threshold	a
Atrium			
<20 ft in height	0.39	NA	REQ
≥20 ft and ≤40 ft in height	0.48	NA	REQ
>40 ft in height	0.60	11	REQ
Audience Seating Area			
Auditorium	0.61	6	REQ
Gymnasium	0.23	6	REQ
Motion picture theater	0.27	4	REQ
Penitentiary	0.67	4	REQ
Performance theater	1.16	8	REQ

Informative Note: This table is divided into two sections; the first section covers space types that can be commonly found in multiple building types. The second part of this table covers space types that are typically found in a single building type.

The control function, Section 9.1.1, (1) All RECs shall (2) At least one (3) At least one

Local Control (See Section 9.1)

Quiz #21

Question: Specified lighting in a 400ft² hotel guest room includes a bathroom fixture rated at 18 Watt and a hallway fixture rated at 22 Watt. No other lighting is shown on drawings. What lighting power should be modeled in the proposed design?

- A. 0.1 W/ft²
- B. 0.41 W/ft²
- C. 0.51 W/ft²
- D. 0.6 W/ft²

Relative Performance – Proposed

Table 9.6.1 *Lighting Power Density*

Informative Note: This table is divided into two sections; this first section covers *space* types that can be commonly found in multiple *building* types. The second section covers *space* types that are typically found in a single *building* type.

Common <i>Space</i> Types ¹	LPD, W/ft ²
Electrical/Mechanical Room ⁷	0.43
Emergency Vehicle Garage	0.52
Food Preparation Area	1.09
Guest Room	0.41

Quiz #21

Answer: B 0.41 W/ ft²

The specified lighting is $(18+22)/400=0.1$ W/ft² and does not serve the entire guest room, and is meant to be supplemented by plug-in table, floor and nightstand lamps. The guest room lighting of 0.41 W/ft² must be modeled in the proposed design based on the guest room allowance in 90.1 Table 9.6.1.

Relative Performance – Proposed

Table 9.6.1 *Lighting Power Density*

Informative Note: This table is divided into two sections; this first section covers *space* types that can be commonly found in multiple *building* types. The second section covers *space* types that are typically found in a single *building* type.

Common <i>Space</i> Types ¹	LPD, W/ft ²
Electrical/Mechanical Room ⁷	0.43
Emergency Vehicle Garage	0.52
Food Preparation Area	1.09
Guest Room	0.41
Laboratory	

Exempt Lighting

9.1.1 Scope

This section shall apply to the following:

- a. Interior *spaces* of *buildings*.
- b. Exterior lighting that is powered through the *building's* electrical *service*.

Exception to 9.1.1

- 1. Emergency lighting that is *automatically* off during normal *building* operation.
 - 2. Lighting, including exit signs, that is specifically designated as required by a health or life safety statute, ordinance, or regulation.
 - 3. Decorative gas *lighting* systems.
-

Lighting Exempt from 90.1. Section 9.1.1 Exception 2 excludes from the scope of the Standard 90.1 any lighting that is specifically designated as required by a health or life safety statute, ordinance, or regulation. With AHJ approval, such lighting, as well as other exempt lighting, may be modeled as an unregulated load, the same in the baseline and proposed design.

Relative Performance – Proposed

Temporary Lighting

Where temporary or partial lighting is specified for core and shell spaces, lighting power in the proposed design must be equal to the allowance in Table 9.6.1, Space-by-Space method where space types are known and using Table 9.5.1 Building Area Method when space types are not known as for core and shell projects.

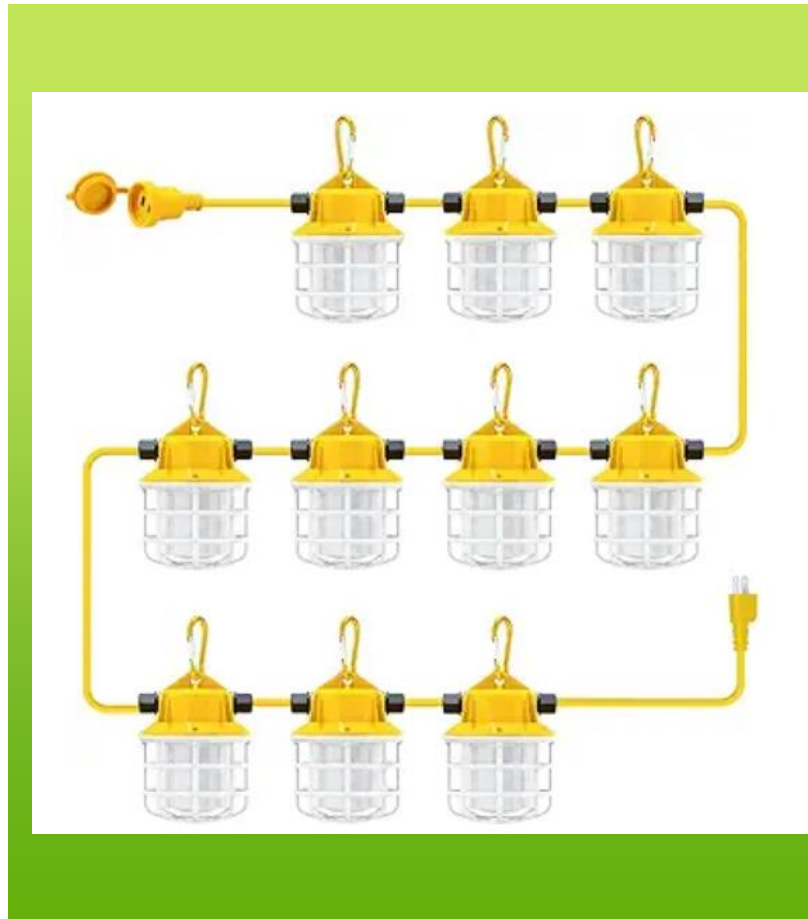

Relative Performance – Proposed

Quiz #22

Question: Core and shell project includes a 3,000 ft² area that will be a retail store. The area has temporary lighting with a total power of 1,000 W. The permanent lighting system will be designed and installed by the future tenant. What lighting power should be modeled in the proposed design?

- A. 0.84 W/ft²
- B. 0.33 W/ft²
- C. 1.17 W/ft²
- D. 1.05 W/ft²

Relative Performance – Proposed

Quiz #22

Answer: A 0.84 W/ft²

The lighting power allowance for retail building area type in Section 9 is 0.84 W/ft² (Table 9.5.1). The specified temporary lighting is $1,000/3,000=0.33$ W/ft² which is lower than this allowance. The retail area must be modeled with 0.84 W/ft² lighting power density in the proposed design.

Note that the baseline must be modeled with 1.50 W/ft² lighting power density based on 90.1 Table G3.8.

Relative Performance – Proposed

Table 9.5.1 Lighting Power Density Allowances Using the Building Area Method

Building Area Type ^a	LPD, W/ft ²
Parking garage	0.18
Penitentiary	0.69
Performing arts theater	0.84
Police station ¹	0.66
Post office	0.65
Religious facility	0.67
Retail	0.84
School/university	0.72
Sports arena	0.76

Table 9.5.1 Lighting Power Density Allowances Using the Building Area Method

Building Area Type ^a	LPD, W/ft ²
Performing arts theater	0.84
Police station	0.66
Post office	0.65
Religious facility	0.67
Retail	0.84
School/university	0.72

Proposed Lighting Controls (Table G3.7)

Automatic lighting controls are required by Standard 90.1 in most space types (90.1 Section 9.4.1 and Table 9.6.1). Since these provisions are mandatory, where such controls are required (if exceptions to these sections do not apply), they must be specified in the proposed design.

Table G3.7 Performance Rating Method Lighting Power Density Allowances and Occupancy Sensor Reductions Using the Space-by-Space Method

Common Space Types ^a	Lighting Power Density, W/ft ²	Occupancy Sensor Reduction ^b
Audience Seating Area		
Auditorium	0.90	10%
Convention center	0.70	10%
Exercise center	0.30	10%
Gymnasium	0.40	10%
Motion picture theater	1.20	10%
Penitentiary	0.70	10%

Lighting controls other than daylighting must be modeled by reducing the lighting schedule each hour by the occupancy sensor reduction factors in 90.1 Table G3.7 Occupancy Sensor Reduction column. Based on the footnotes below the table, the occupancy sensor reduction factor must be multiplied by 1.25 for manual-on or partial-auto-on occupancy sensors; for occupancy sensors controlling individual workstation lighting, occupancy sensor reduction factor of 30% must be used.

Relative Performance – Proposed

Modeling Lighting Controls Other Than Daylighting

MA Stretch 2023 Amendments

Projects following MA Stretch may also document credit for the following automatic lighting controls included in the proposed design that are not required by Section 9.4.1 and Table 9.6.1:

- For luminaire that meet requirements of C406.4 (enhanced digital lighting controls) the occupancy sensor reduction factor may be increased by 7.5%.
- For lighting in the dwelling units that have controls meeting all of the following requirements, an occupancy sensor reduction factor of 10% may be used.
 - Each dwelling unit has a main control by the main entrance that turns off all the lights and all switched receptacles in the dwelling unit.
 - The main control may have two controls, one for permanently wired lighting and one for switched receptacles.
 - Where controls are divided the main controls must be clearly identified as “lights master of” and “outlets master of.”

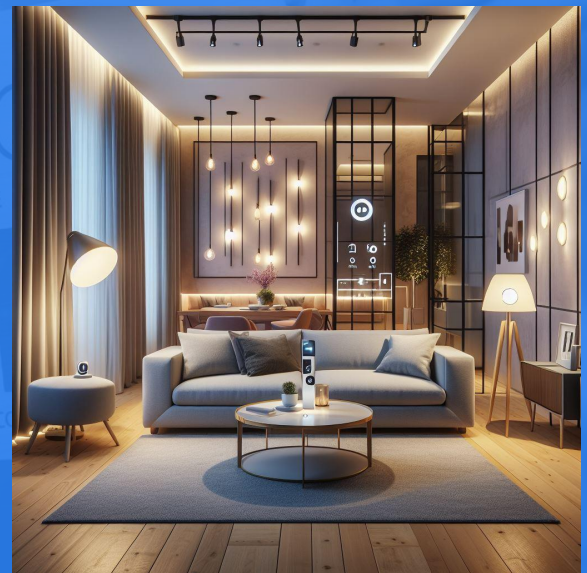

Relative Performance – Proposed

Modeling Daylighting Controls

- Automatic daylight responsive controls are required for most spaces with vertical fenestration and skylights according to 90.1 Section 9.4.1 and Table 9.6.1.
- May be modeled directly or via schedule adjustment determined by an approved analysis.
- If a separate analysis was performed, such as using a specialized daylighting software, the summary outputs from such software and explanation of how the results were incorporated into the whole building simulation must be included in the submittal.
 - Schedule adjustments must be applied only to the fixtures for which daylight controls are specified.
 - Visual light transmittance (VT) of the specified windows affects daylighting savings and must be captured in the tool used to calculate savings.

The screenshot shows the 'Space Properties' dialog box for 'EL1 NNE Perim Spc (G.NNE1)'. The 'Daylighting' section is set to 'Yes'. The 'Lighting Controls' section shows 'System 1 Scenario' as 'Switch: 3Level+Off' and 'System 2 Scenario' as 'DOE-2 Default or User Specified'. The 'Discrete Step Controls' table is as follows:

	Input Pwr System 1	Output Illum 1	Input Pwr System 2	Output Illum 2
1	1.000	1.000	n/a	n/a
2	0.667	0.667	n/a	n/a
3	0.333	0.333	n/a	n/a
4	0.000	0.000	n/a	n/a
5			n/a	n/a

The 'Control Reference Points & Settings' section shows the following values:

	Controlled kW Fraction	Light Set Point (fc)	Discomfort Max Value	Glare View Azimuth	Control System Operation Mode	Control Reference Position: X	Control Reference Position: Y	Control Reference Position: Z
System 1:	0.89	50	100	0.0	Discrete Steps	30.0	9.9	2.5
System 2:		n/a	n/a	n/a	n/a	n/a	n/a	2.5

Relative Performance – Proposed



Interior Lighting: Baseline Design

Interior Lighting Power

Lighting Power

- Lighting power density (LPD) from Table G3.7 using **space-by-space method**.
- Table G3.8, Building Area Method, may only be used for portions of the building where lighting is not specified and space types are unknown, as with core-and-shell projects.
- No allowance for decorative lighting even when specified in the proposed design.
- Where retail display lighting is included in the proposed building design in accordance with Section 9.6.2b, the baseline building design retail display lighting additional power should be equal to the limits established by Section 9.6.2b or same as proposed which ever less (90.1 2019 addendum af).

Table G3.7 Performance Rating Method Lighting Power Density Allowances and Occupancy Sensor Reductions Using the Space-by-Space Method

Common Space Types ^a	Lighting Power Density, W/ft ²	Occupancy Sensor Reduction ^b
Audience Seating Area		
Corridor		
Facility for the visually impaired (and used primarily by residents)	1.15	25%
Hospital	1.00	25%
Manufacturing facility	0.50	25%
A other corridor	0.50	25%
Electrical/Mechanical Room	1.50	30%
Emergency Vehicle Garage	0.80	10%
Food Preparation Area	1.20	30%
Guest Room	1.14	45%
Judges Chambers	1.30	30%

Table G3.8 Performance Rating Method Lighting Power Densities Using the Building Area Method

Building Area Type	Lighting Power Density, W/ft ²
Automotive facility	0.90
Convention center	1.20
Courthouse	1.20
Dining: Bar lounge/leisure	1.30
Dining: Cafeteria/fast food	1.40
Dining: Family	1.60
Dormitory	1.00
Exercise center	1.00
Fire station	1.00
Gymnasium	1.10
Health-care clinic	1.00

Relative Performance – Baseline

Interior Lighting Controls

Lighting Controls

- No automatic daylighting controls
- Automatic shutoff controls in buildings > 5000 ft²
- Occupancy sensors in employee lunch and break rooms, conference/meeting rooms, and classrooms (excluding shop classrooms, laboratory classrooms, and K-12 classrooms) must be modeled by using the same lighting schedule for these spaces as in the proposed design.

Relative Performance – Baseline

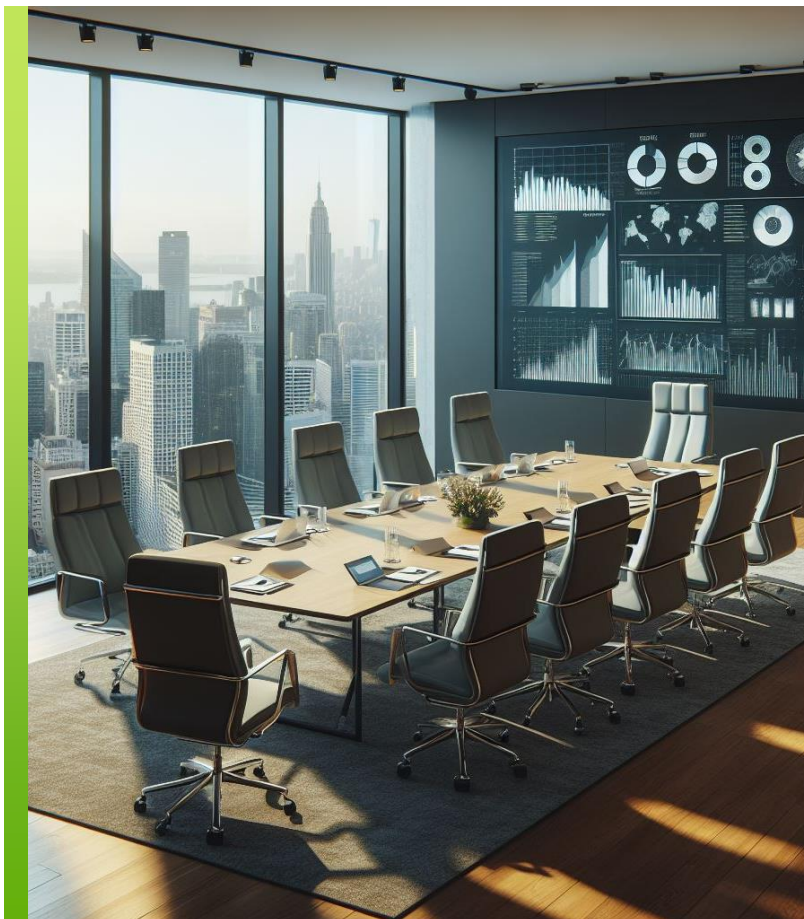

Quiz #23

Question: A 175 ft² enclosed office has occupancy sensor (OS) and automatic daylighting dimming controls specified in the proposed design. How should lighting controls be modeled in the baseline and proposed models?

- A. Schedules should be modeled identically in the baseline and proposed models and to reflect lighting controls since OS controls are mandatory requirements in 90.1 2019. Daylighting controls should only be modeled in the proposed design model.
- B. Schedules should be modeled identically in the baseline and proposed models to reflect lighting controls since OS controls are mandatory requirements in 90.1 2019. Daylighting controls should be modeled in both the baseline and proposed models.
- C. Schedules should be modeled to reflect lighting controls only in the proposed design model. Daylighting controls should only be modeled in the proposed design model.

Quiz #23

Question: A 175 ft² enclosed office has occupancy sensor (OS) and automatic daylighting dimming controls specified in the proposed design. How should lighting controls be modeled in the baseline and proposed models?

- A. Schedules should be modeled identically in the baseline and proposed models and to reflect lighting controls since OS controls are mandatory requirements in 90.1 2019. Daylighting controls should only be modeled in the proposed design model.
- B. Schedules should be modeled identically in the baseline and proposed models to reflect lighting controls since OS controls are mandatory requirements in 90.1 2019. Daylighting controls should be modeled in both the baseline and proposed models.
- C. Schedules should be modeled to reflect lighting controls only in the proposed design model. Daylighting controls should only be modeled in the proposed design model.

Occupancy sensor lighting controls are only required to be modeled in the baseline for employee lunch and break rooms, conference/meeting rooms, and classrooms (not including shop classrooms, laboratory classrooms, and preschool through 12th-grade classrooms) so lighting controls do not need to be reflected in the baseline schedules for this space.

In terms of the proposed, lighting control credits from Table G3.7 can be reflected in the proposed design lighting schedules whenever OS are specified for a space.

With respect to daylighting, daylighting controls are never modeled in the baseline and are modeled in the proposed design if specified.

Exterior Lighting

90.1 Mandatory Requirements

Exterior lighting controls (Sections 9.4.1.4)

- Automatically turn off lights when sufficient daylighting is available
- Automatically shut off façade and landscape lighting during prescribed periods depending on business operating hours
- Bi-level lighting control for certain outdoor parking areas and signage.

Exterior building lighting power (Section 9.4.2)

- Depends on the project lighting zone
- Specified **tradable lighting must not exceed the sum of base and tradable allowances**
- Specified non-tradeable lighting (e.g., for building facades) **must not exceed the individual allowances**

Table 9.4.2-2 Individual Lighting Power Allowances for Building Exteriors

	Zone 0	Zone 1	Zone 2	Zone 3	Zone 4
Base Site Allowance (Base allowance may be used in tradable or nontradable surfaces.)					
	No allowance	350 W	400 W	500 W	900 W
Tradable Surfaces (LPD allowances for uncovered parking areas, building grounds, building entrances, exits and loading docks, canopies and overhangs, and outdoor sales areas may be traded.)					
Uncovered Parking Areas					
Parking areas and drives	No allowance	0.03 W/ft ²	0.04 W/ft ²	0.06 W/ft ²	0.08 W/ft ²
Building Grounds					
Walkways/ramps less than 10 ft wide	No allowance	0.5 W/linear foot	0.5 W/linear foot	0.6 W/linear foot	0.7 W/linear foot
Walkways/ramps 10 ft wide or greater Plaza areas Special feature areas	No allowance	0.10 W/ft ²	0.10 W/ft ²	0.11 W/ft ²	0.14 W/ft ²
Nontradable Surfaces (LPD allowances for the following applications can be used only for the specific application and cannot be traded between surfaces or with other exterior lighting. The following allowances are in addition to any allowance otherwise permitted in the "Tradable Surfaces" section of this table.)					
<i>Building facades</i> (The allowance for each illuminated facade orientation shall be calculated by multiplying the allowable value by the entire facade area or facade length for that orientation.)	No allowance	No allowance	0.1 W/ft ² of facade area or 2.5 W/linear foot of facade length	0.15 W/ft ² of facade area or 3.75 W/linear foot of facade length	0.2 W/ft ² of facade area or 5.0 W/linear foot of facade length
Automated teller machines and night depositories	No allowance	135 W per location plus 45 W per additional ATM per location	135 W per location plus 45 W per additional ATM per location	135 W per location plus 45 W per additional ATM per location	135 W per location plus 45 W per additional ATM per location

Other MA Stretch 2023 Mandatory Requirements

Code Requirement

C405 Electric Power and Lighting Systems

Interior and exterior lighting power and controls; electric metering; transformers; motors; vertical and horizontal transportation systems and equipment; voltage drop; automatic receptacle controls; energy monitoring; provisions for the electric vehicles ready parking spaces.

(Reminder from 4-Hour Training)



Exterior Lighting: Proposed Design

Proposed Design Lighting Power



Exterior lighting power allowances and control requirements are mandatory in 90.1. Thus, the specified exterior lighting may improve over the allowances in 90.1 Table 9.4.2-2 but must not perform worse than the requirements.

The allowances in Table 9.4.2-2 depend on the Exterior Lighting Zones that are based on project location. Most projects in MA are expected to use either Zone 2 or Zone 3 allowances based on zone description in 90.1 Table 9.4.2-1:

- **Zone 2:** Areas predominantly consisting of residential zoning, neighborhood business districts, light industrial with limited nighttime use and residential mixed-use areas.
- **Zone 3:** All other areas excluding exterior lighting in national state parks, forest land and rural areas and high activity commercial districts in major metropolitan areas.
- **Zone 4:** High-activity commercial districts in major metropolitan areas. Using Zone 4 allowances requires approval of the local jurisdiction.

	Zone 0	Zone 1	Zone 2	Zone 3	Zone 4
Base Site Allowance (Base allowance may be used in tradable or nontradable surfaces.)	No allowance	350 W	400 W	500 W	900 W
Tradable Surfaces (LPD allowances for uncovered parking areas, building grounds, building entrances, exits and loading docks, canopies and overhangs, and outdoor sales areas may be traded.)					
Uncovered Parking Areas					
Parking areas and drives	No allowance	0.03 W/ft ²	0.04 W/ft ²	0.06 W/ft ²	0.08 W/ft ²
Building Grounds					
Walkways/ramps less than 10 ft wide	No allowance	0.5 W/linear foot	0.5 W/linear foot	0.6 W/linear foot	0.7 W/linear foot
Walkways/ramps 10 ft wide or greater	No allowance	0.10 W/ft ²	0.10 W/ft ²	0.11 W/ft ²	0.14 W/ft ²

Relative Performance – Proposed

Proposed Design Lighting Controls

Following Section 9.4.1.4, the exterior lighting must be controlled to turn off when sufficient lighting is available and turned off, or operate at wattage reduced by at least 50%, during non-business hours. These controls are mandatory and must be specified on all projects.

Following these requirements, the modeled exterior lighting runtime may be up to 12 hours / day (4,380 hours per year) for facilities opened 24/7, such as hospitals. Lower runtime is expected for other building types due to lighting control requirements in 90.1 Section 9.4.1.



Relative Performance – Proposed

Exterior Lighting: Baseline Design

Baseline Design Exterior Lighting

- The lighting allowances in Table G3.6 for all tradable applications must be multiplied by the associated area or length to determine the total baseline power allowance. Only illuminated areas can be included in the calculations of the baseline wattage.
- The baseline power for the non-tradable lighting applications must be the same as in the proposed design.
- Exterior lighting runtime hours must be modeled the same as in the proposed design.

Table G3.6 Performance Rating Method Lighting Power Densities for Building Exteriors

Tradable Surfaces (Lighting power densities for uncovered parking areas, building grounds, building entrances and exits, canopies and overhangs and outdoor sales areas may be traded.)	Uncovered Parking Areas	
	Parking lots and drives	0.15 W/ft ²
	Building Grounds	
	Walkways less than 10 ft wide	1.0 W/linear foot
	Walkways 10 ft wide or greater	0.2 W/ft ²
	Plaza areas	
	Special feature areas	
	Stairways	1.0 W/ft ²
	Building Entrances and Exits	
	Main entries	30 W/linear foot of door width
	Other doors	20 W/linear foot of door width
	Canopies and Overhangs	
	Canopies (free standing and attached and overhangs)	1.25 W/ft ²
Outdoor Sales		
Open areas (including vehicle sales lots)	0.5 W/ft ²	
Street frontage for vehicle sales lots in addition to open-area allowance	20 W/linear foot	
Nontradable Surfaces (Lighting power density calculations for the following applications can		0.2 W/ft ² for each illuminated wall or surface or 5.0 W/linear foot for each illuminated wall or surface length
Building Façades		
Automated Teller Machines (ATMs) and		270 W per location plus 90 W per additional

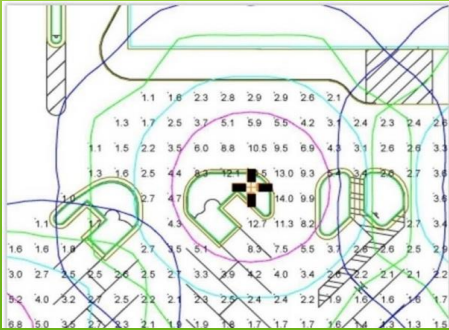

Relative Performance –
Baseline/Proposed

Common Mistakes with Determining Exterior Lighting Allowance

- Calculating exterior lighting allowance based on the areas of the surfaces in the proposed design that are not illuminated to some industry standard, such as the IESNA Handbook, or incorrectly accounting for partially illuminated areas.
- Double-counting areas when calculating the exterior lighting power allowance. Lighting power allowance for a walkway that crosses an illuminated parking lot can be determined based on the parking lot allowance or walkway allowance in 90.1 Table G3.6, but not both. If walkway allowance is used, the walkway area must be subtracted from the parking lot area.
- Modeling baseline lighting for non-tradable surfaces based on the full allowance in 90.1 Table G3.6. The baseline non-tradable lighting must be modeled the same as in the proposed design.

Quiz #24

Question: Project involves a retail store with a parking lot. The specified exterior lighting fixtures have the total rated power of 1,000 W and mounting height of 20'. What hours of operation should be modeled for these fixtures?

- A. 4,380 annually
- B. 2,555 annually



Relative Performance – Baseline/Proposed

Quiz #24

Answer: B, 2555 Based on Section 9.4.1.4(a), lighting must be turned of when sufficient lighting is available, which is typically assumed to be 12 hours per day on average. During the remaining 12 hours, lighting controls required by Section 9.4.1.4 (d) must automatically reduce the power of each luminaire by a minimum of 50% when no activity has been detected in the area illuminated by the controlled luminaires for a time of no longer than 15 minutes. To reflect these mandatory controls that must be specified in the proposed design, modeler may assume that parking lot fixtures run at 50% of the rated power for 10 hours and 100% of the rated power for 2 hours. These assumptions are equivalent to 7 full load hours. $7 * 365 = 2555$ hours



Relative Performance – Baseline/Proposed



Process and Plug Loads

Process and Plug Loads Definition

The process and plug loads category includes systems and equipment that impact building energy use but are not regulated by ASHRAE Standard 90.1, such as

- consumer appliances,
- miscellaneous plug-in systems,
- IT equipment, etc.

These systems contribute to internal heat gains which impact heating and cooling loads on the HVAC systems.

Process and plug loads must be the same in the baseline and proposed design models.



Process and Plug Loads Definition

There are a small number of building components that fall into the process and plug loads category that are regulated in 90.1 including:

- Commercial refrigeration
- Escalators and elevators
- Transformers
- Receptacle controls

Credit can be modeled for these systems and components.



Annex 1: Reference Site EUI By End Use

These tables are provided for reference and are based on the energy consumption by end use of the PNNL prototype models in Climate Zone 5A minimally compliant with 90.1 2004 (analogous to 90.1 Appendix G baseline) and 90.1 2019 (analogous but less efficient than design minimally compliant with the MA Stretch Code.)

Table 1.1: Site EUI [kBtu/SF] of Designs Minimally Compliant with ASHRAE 90.1 2004 in CZ5A

Building Type	Interior Lighting	Exterior Lighting	SHW	Heating	Cooling	Fans	Pumps	Refrigeration	Elevators	Transformers	Process & Plug	Total
Highrise Apartment	3.8	2.4	13.8	30.2	1.9	3	0.7	0	1.8	0.4	11	69
Midrise Apartment	3.9	2	11.9	22.7	2.3	2.5	0	0	3.6	0	10.9	59.9
Hospital	16.4	1	5.3	64.5	12.4	17.2	4.2	1	10	0.7	38.6	171.3
Large Hotel	11.3	2.4	17.9	32.5	9.6	13.8	1.4	0.8	7.6	0.4	27.2	125
Small Hotel	10.9	2.1	14.3	15.7	5.9	6.8	0	0	5.7	0	16.8	78.2
Large Office	9.8	1.9	1.2	16.4	8.7	4.5	1.3	0	3.7	0.3	28.9	76.7
Medium Office	9.8	4	1.6	16.9	3.9	1.7	0	0	3.1	0.6	11.3	53
Small Office	12.2	4.3	3.1	9.5	2.9	4	0	0	0	0	9.1	45
Outpatient Healthcare	14.2	5.3	5.9	50.3	14.8	12.7	0.1	0	15.1	0	32.2	150.6
Standalone Retail	18.9	4.4	3.8	32.9	6.3	18	0	0	0	0	7.5	91.8
Strip Mall	26.6	7	3	45.5	5.2	10.5	0	0	0	0	5.4	103.2
Primary School	15.5	1.1	2	26.6	6.1	9.9	0.1	1.7	0	0.6	20.6	84.3
Secondary School	14.8	1	3.1	15.7	7	11	0.5	0.9	0.3	0.4	13.6	68.3
Warehouse	8.8	2.2	0.5	26.7	0.3	1.1	0	0	0	0	2.5	42.2

Table 1.2: Site EUI [kBtu/SF] of Designs Minimally Compliant with ASHRAE 90.1 2019 in CZ5A

Building Type	Interior Lighting	Exterior Lighting	SHW	Heating	Cooling	Fans	Pumps	Refrigeration	Elevators	Transformers	Process & Plug	Total
Highrise Apartment	2.3	1.3	13.8	11.1	1.6	2.2	0.4	0	1.8	0.2	10.9	45.5
Midrise Apartment	2.3	0.7	11.9	6.6	1.7	1.9	0	0	3.5	0	10.8	39.6
Hospital	12.9	0.6	5.2	18.9	8	12.2	1.1	0.5	9.8	0.3	37.9	107.4
Large Hotel	4.1	1.4	17.9	4.6	4.7	5.9	0.4	0.5	7.4	0.2	26.6	73.5
Small Hotel	4	1	14.2	5.8	4.1	3.4	0	0	5.5	0	16	54
Large Office	4.9	0.7	1.2	4	5.2	3.9	0.5	0	3.6	0.1	27.9	51.9
Medium Office	4.4	0.8	1.6	7.2	2.5	1.1	0	0	2.9	0.2	10.3	31.1
Small Office	4.4	1	3.1	5.2	1.6	2.7	0	0	0	0	8.3	26.2
Outpatient Healthcare	8.8	1.3	5.3	24.6	10.1	7.8	0.1	0	14.8	0	31.9	104.7
Standalone Retail	9.2	1.5	3.7	23.8	3	5.7	0	0	0	0	7.5	54.3
Strip Mall	17	2.5	2.7	28.4	2.4	5.2	0	0	0	0	5.4	63.6
Primary School	3.7	0.3	2	7.5	2.9	4.5	0.1	0.9	0	0.2	18.7	40.8
Secondary School	3.7	0.3	3.1	5.2	3.9	4.6	0.1	0.5	0.3	0.1	12.7	34.6
Warehouse	3	1	0.5	18.1	0.1	0.7	0	0	0	0	2.5	26

90.1 Mandatory Requirements

- Feeder conductors and branch circuits must be sized for a maximum 5% total voltage drop (Section 8.4.1)
- Automatic receptacle controls must be specified for the following applications (Section 8.4.2)
 - At least 50% of all 125 V, 15 and 20 amp receptacles in private offices, conference rooms, rooms used primarily for printing and/or copying, break rooms, classrooms, and individual workstations.
 - At least 25% of *branch circuit* feeders installed for modular furniture not shown on the *construction documents*.
- Minimum efficiency requirements for low-voltage dry-type distribution transformers (Section 8.4.4)
- Minimum efficiency requirements for electric motors (Section 10.4.1)
- Service water pressure booster system controls (Section 10.4.2)

90.1 Mandatory Requirements (Continued)

- Requirements for elevators including cab lighting and ventilation power allowances and occupancy controls, and required details that must be included in design documents such as usage category and energy efficiency class based on ISO 25745 (Section 10.4.3)
- Controls for escalator and moving walks (Section 10.4.4)
- Testing and controls required for air curtains (Section 10.4.5)
- Energy use monitoring in new buildings
 - Separately monitor electricity use for HVAC systems, interior lighting, exterior lighting, receptacle circuits and the total. For buildings with tenants, separate monitoring is required for each individual tenant, except for the shared systems. (Section 8.4.3)
 - Exceptions: Buildings less than 25,000 ft², individual tenant spaces less than 10,000 ft², dwelling units, residential buildings with less than 10,000 ft² common area
 - Monitoring whole building use of natural gas, fuel oil, propane, steam, chilled water and hot water (Section 10.4.6)

Other MA Stretch 2023 Mandatory Requirements

Code Requirement

C405 Electric Power and Lighting Systems

Interior and exterior lighting power and controls; electric metering; transformers; motors; vertical and horizontal transportation systems and equipment; voltage drop; automatic receptacle controls; energy monitoring; provisions for the electric vehicles ready parking spaces.

(Reminder from 4-Hour Training)

Modeling Requirements

Receptacle and process loads must be modeled and estimated based on the building area type or space type category.

All end-use load components within and associated with the building must be modeled, including but not limited to exhaust fans, parking garage ventilation fans, swimming pool heaters and pumps, elevators and escalators, refrigeration equipment, and cooking equipment.



Common Mistakes for Plug and Process Loads

- Elevators are regulated by 90.1 and must be modeled as prescribed in Table G3.1 #16.
- Commercial refrigeration equipment is regulated by 90.1 and must be modeled as prescribed in Table G3.1 #17.
- Transformers are regulated by 90.1 and must be modeled as prescribed in Table G3.1 #15 (credit can be modeled where projects perform better than mandatory requirements in Table 8.4.4)
- Credit can be modeled when receptacle controls are specified in spaces where not required by 90.1 Section 8.4.2 according to Table G3.1 #12.

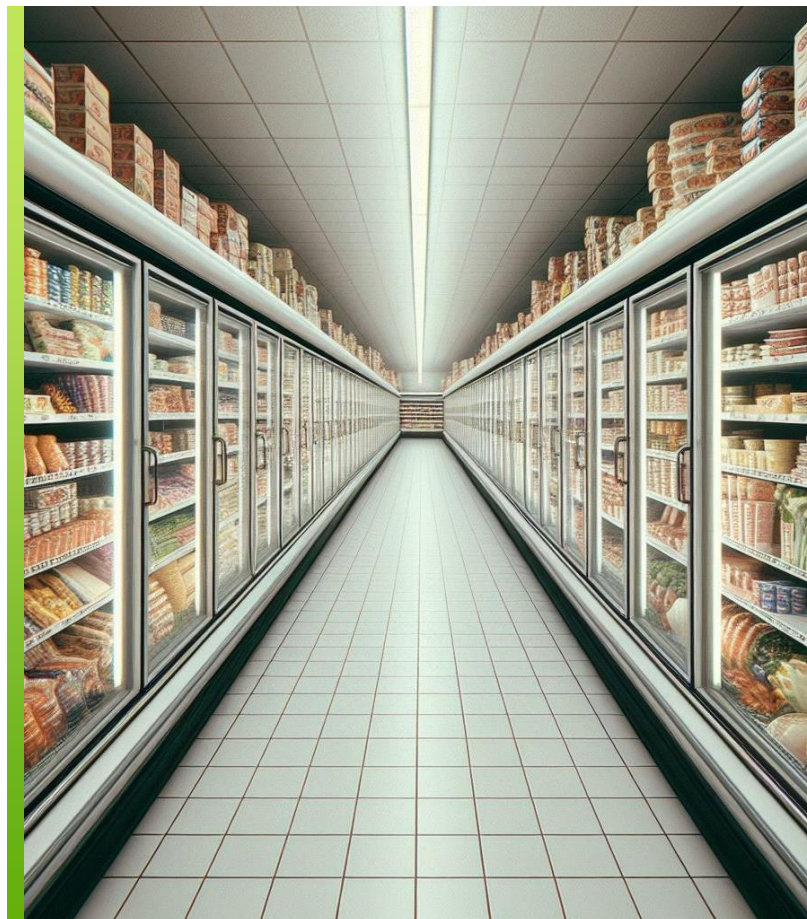

Refrigeration Systems

Where refrigeration equipment is specified in the proposed design and listed in Tables G3.10.1 and G3.10.2, the baseline building design must be modeled as specified in Tables G3.10.1 and G3.10.2 using the actual equipment volumes and display areas.

If the refrigeration equipment is not listed in Tables G3.10.1 and G3.10.2, the baseline building design must be modeled the same as the proposed design.

Table G3.10.1 Performance Rating Method Commercial Refrigerators and Freezers

Equipment Type	Application	Energy Use Limits, kWh/day	Test Procedure
Refrigerator with solid doors	Holding temperature	$0.125 \times V + 2.76$	AHRI 1200
Refrigerator with transparent doors		$0.172 \times V + 4.77$	
Freezers with solid doors		$0.398 \times V + 2.28$	
Freezers with transparent doors		$0.94 \times V + 5.10$	
Refrigerators/freezers with solid doors		$0.12 \times V + 4.77$	
Commercial refrigerators	Pulldown	$0.181 \times V + 5.01$	

Table G3.10.2 Performance Rating Method Commercial Refrigeration

Equipment Type		Operating Mode	Rating Temperature	Energy Use Limits, kWh/day ^{b,c}	Test Procedure
Equipment Class ^a	Family Code				
VOP.RC.M	Vertical open	Remote condensing	Medium temperature	$1.01 \times TDA + 4.07$	AHRI 1200
SVO.RC.M	Semivertical open	Remote condensing	Medium temperature	$1.01 \times TDA + 3.18$	
HZO.RC.M	Horizontal open	Remote condensing	Medium temperature	$0.51 \times TDA + 2.88$	
VOP.RC.L	Vertical open	Remote condensing	Low temperature	$2.84 \times TDA + 6.85$	
HZO.RC.L	Horizontal open	Remote condensing	Low temperature	$0.68 \times TDA + 6.88$	
VCT.RC.M	Vertical transparent door	Remote condensing	Medium temperature	$0.48 \times TDA + 1.95$	
VCT.RC.L	Vertical transparent door	Remote condensing	Low temperature	$1.03 \times TDA + 2.61$	
SOC.RC.M	Service over counter	Remote condensing	Medium temperature	$0.62 \times TDA + 0.11$	
VOP.SC.M	Vertical open	Self-contained	Medium temperature	$2.34 \times TDA + 4.71$	
SVO.SC.M	Semivertical open	Self-contained	Medium temperature	$2.23 \times TDA + 4.59$	
HZO.SC.M	Horizontal open	Self-contained	Medium temperature	$1.14 \times TDA + 5.55$	
HZO.SC.L	Horizontal open	Self-contained	Low temperature	$2.63 \times TDA + 7.08$	
VCT.SC.I	Vertical transparent door	Self-contained	Ice cream	$1.63 \times TDA + 3.29$	
VCS.SC.I	Vertical solid door	Self-contained	Ice cream	$0.55 \times V + 0.88$	
HCT.SC.I	Horizontal transparent door	Self-contained	Ice cream	$1.22 \times TDA + 0.42$	

Modeling Refrigeration Systems

- Baseline energy use (kWh/day) must be as prescribed in 90.1 Table G3.10.1 and G3.10.2 for the specified equipment type and size.
- Proposed energy use must reflect the AHRI 1200 kWh/day rating for the specified equipment from equipment manufacturer.
- The hourly refrigeration load (RL) entered into simulation tool must be determined as follows, assuming uniform year-round operation:
 $RL = RP/24$ (RL will be determined separately for the baseline and proposed)
 Where:
 RL [kW/hr] = refrigeration load,
 RP [kWh/day] = rated performance, based on Tables G3.10.1 or G3.10.2 for the baseline and based on AHRI 1200 rating of the specified equipment for the proposed design.
- The schedules used in the baseline and proposed design in conjunction with the refrigeration load must have hourly fractions of 1 for all hours of the year.
- If the specified refrigeration equipment has remote condensers, the internal gains to the spaces where equipment is located must be adjusted to reflect amount of heat extracted from the space as appropriate for the specified equipment. The same internal gains adjustment must be used for the baseline design as for the proposed design. See the [2019 PNNL PRM Reference Manual](#) for a methodology for accounting for refrigeration gains.

Quiz #25

Question: What kWh/day should be modeled in the baseline model for a self-contained, horizontal, ice cream commercial refrigeration unit with a solid door with the following dimensions L = 4 ft, W = 2 ft, and D = 2 ft?

- A. Same as proposed.
- B. 9.68 kWh/day
- C. 5.28 kWh/day
- D. 3.08 kWh/day

Table G3.10.2 Performance Rating Method Commercial Refrigeration

Equipment Type					
Equipment Class ^a	Family Code	Operating Mode	Rating Temperature	Energy Use Limits, ^{b,c} kWh/day	Test Procedure
VOP.RC.M	Vertical open	Remote condensing	Medium temperature	1.01 × TDA + 4.07	AHRI 1200
SVO.RC.M	Semivertical open	Remote condensing	Medium temperature	1.01 × TDA + 3.18	
HZO.RC.M	Horizontal open	Remote condensing	Medium temperature	0.51 × TDA + 2.88	
VOP.RC.L	Vertical open	Remote condensing	Low temperature	2.84 × TDA + 6.85	
HZO.RC.L	Horizontal open	Remote condensing	Low temperature	0.68 × TDA + 6.88	
VCT.RC.M	Vertical transparent door	Remote condensing	Medium temperature	0.48 × TDA + 1.95	
VCT.RC.L	Vertical transparent door	Remote condensing	Low temperature	1.03 × TDA + 2.61	
SOC.RC.M	Service over counter	Remote condensing	Medium temperature	0.62 × TDA + 0.11	
VOP.SC.M	Vertical open	Self-contained	Medium temperature	2.34 × TDA + 4.71	
SVO.SC.M	Semivertical open	Self-contained	Medium temperature	2.23 × TDA + 4.59	
HZO.SC.M	Horizontal open	Self-contained	Medium temperature	1.14 × TDA + 5.55	
HZO.SC.L	Horizontal open	Self-contained	Low temperature	2.63 × TDA + 7.08	
VCT.SC.I	Vertical transparent door	Self-contained	Ice cream	1.63 × TDA + 3.29	
VCS.SC.I	Vertical solid door	Self-contained	Ice cream	0.55 × V + 0.88	
HCT.SC.I	Horizontal transparent door	Self-contained	Ice cream	1.33 × TDA + 0.43	
SVO.RC.L	Semivertical open	Remote condensing	Low temperature	2.84 × TDA + 6.85	
VOP.RC.I	Vertical open	Remote condensing	Ice cream	3.6 × TDA + 8.7	
SVO.RC.I	Semivertical open	Remote condensing	Ice cream	3.6 × TDA + 8.7	
HZO.RC.I	Horizontal open	Remote condensing	Ice cream	0.87 × TDA + 8.74	
VCT.RC.I	Vertical transparent door	Remote condensing	Ice cream	1.2 × TDA + 3.05	
HCT.RC.M	Horizontal transparent door	Remote condensing	Medium temperature	0.39 × TDA + 0.13	AHRI 1200
HCS.RC.I	Horizontal solid door	Remote condensing	Ice cream	0.39 × V + 0.63	
SOC.RC.L	Service over counter	Remote condensing	Low temperature	1.3 × TDA + 0.22	
SOC.RC.I	Service over counter	Remote condensing	Ice cream	1.52 × TDA + 0.26	
VOP.SC.L	Vertical open	Self contained	Low temperature	5.87 × TDA + 11.82	
VOP.SC.I	Vertical open	Self-contained	Ice cream	7.45 × TDA + 15.02	
SVO.SC.L	Semivertical open	Self-contained	Low temperature	5.59 × TDA + 11.51	
SVO.SC.I	Semivertical open	Self-contained	Ice cream	7.11 × TDA + 14.63	
HZO.SC.I	Horizontal open	Self-contained	Ice cream	3.35 × TDA + 9.0	
SOC.SC.I	Service over counter	Self-contained	Ice cream	2.13 × TDA + 0.36	
HCS.SC.I	Horizontal solid door	Self-contained	Ice cream	0.55 × V + 0.88	

Quiz #25

Question: What kWh/day should be modeled in the baseline model for a self-contained, horizontal, ice cream commercial refrigeration unit with a solid door with the following dimensions L = 4 ft, W = 2 ft, and D = 2 ft?

- A. Same as proposed.
- B. 9.68 kWh/day = 0.55 * (4x2x2 ft³) + 0.88
- C. 5.28 kWh/day
- D. 3.08 kWh/day

Table G3.10.2 Performance Rating Method Commercial Refrigeration

Equipment Type					
Equipment Class ^a	Family Code	Operating Mode	Rating Temperature	Energy Use Limits, ^{b,c} kWh/day	Test Procedure
VOP.RC.M	Vertical open	Remote condensing	Medium temperature	1.01 × TDA + 4.07	AHRI 1200
SVO.RC.M	Semivertical open	Remote condensing	Medium temperature	1.01 × TDA + 3.18	
HZO.RC.M	Horizontal open	Remote condensing	Medium temperature	0.51 × TDA + 2.88	
VOP.RC.L	Vertical open	Remote condensing	Low temperature	2.84 × TDA + 6.85	
HZO.RC.L	Horizontal open	Remote condensing	Low temperature	0.68 × TDA + 6.88	
VCT.RC.M	Vertical transparent door	Remote condensing	Medium temperature	0.48 × TDA + 1.95	
VCT.RC.L	Vertical transparent door	Remote condensing	Low temperature	1.03 × TDA + 2.61	
SOC.RC.M	Service over counter	Remote condensing	Medium temperature	0.62 × TDA + 0.11	
VOP.SC.M	Vertical open	Self-contained	Medium temperature	2.34 × TDA + 4.71	
SVO.SC.M	Semivertical open	Self-contained	Medium temperature	2.23 × TDA + 4.59	
HZO.SC.M	Horizontal open	Self-contained	Medium temperature	1.14 × TDA + 5.55	
HZO.SC.L	Horizontal open	Self-contained	Low temperature	2.63 × TDA + 7.08	
VCT.SC.I	Vertical transparent door	Self-contained	Ice cream	1.63 × TDA + 3.29	
VCS.SC.I	Vertical solid door	Self-contained	Ice cream	0.55 × V + 0.88	
HCT.SC.I	Horizontal transparent door	Self-contained	Ice cream	1.33 × TDA + 0.43	
SVO.RC.L	Semivertical open	Remote condensing	Low temperature	2.84 × TDA + 6.85	
VOP.RC.I	Vertical open	Remote condensing	Ice cream	3.6 × TDA + 8.7	
SVO.RC.I	Semivertical open	Remote condensing	Ice cream	3.6 × TDA + 8.7	
HZO.RC.I	Horizontal open	Remote condensing	Ice cream	0.87 × TDA + 8.74	
VCT.RC.I	Vertical transparent door	Remote condensing	Ice cream	1.2 × TDA + 3.05	
HCT.RC.M	Horizontal transparent door	Remote condensing	Medium temperature	0.39 × TDA + 0.13	AHRI 1200
HCS.RC.I	Horizontal solid door	Remote condensing	Ice cream	0.39 × V + 0.63	
SOC.RC.L	Service over counter	Remote condensing	Low temperature	1.3 × TDA + 0.22	
SOC.RC.I	Service over counter	Remote condensing	Ice cream	1.52 × TDA + 0.26	
VOP.SC.L	Vertical open	Self contained	Low temperature	5.87 × TDA + 11.82	
VOP.SC.I	Vertical open	Self-contained	Ice cream	7.45 × TDA + 15.02	
SVO.SC.L	Semivertical open	Self-contained	Low temperature	5.59 × TDA + 11.51	
SVO.SC.I	Semivertical open	Self-contained	Ice cream	7.11 × TDA + 14.63	
HZO.SC.I	Horizontal open	Self-contained	Ice cream	3.35 × TDA + 9.0	
SOC.SC.I	Service over counter	Self-contained	Ice cream	2.13 × TDA + 0.36	
HCS.SC.I	Horizontal solid door	Self-contained	Ice cream	0.55 × V + 0.88	

Heating, Ventilation, and Air Conditioning Systems

90.1 Mandatory Requirements: Equipment Efficiency

Specified equipment must meet efficiency requirements in 90.1 Tables 6.8.1-1 to 6.8.1-20 (6.4.1.1)

Table 6.8.1-2 Electrically Operated Air-Cooled Unitary Heat Pumps—Minimum Efficiency Requirements

Equipment Type	Size Category	Heating Section Type	Subcategory or Rating Condition	Minimum Efficiency	Test Procedure ^a
Air cooled (cooling mode)	<65,000 Btu/h	All	Split system, three phase and applications outside U.S. single phase ^b	14.0 SEER before 1/1/2023 14.3 SEER ₂ after 1/1/2023	AHRI 210/240-2017 before 1/1/2023 AHRI 210/240-2023 after 1/1/2023
			Single package, three phase and applications outside U.S. single phase ^b	14.0 SEER before 1/1/2023 13.4 SEER ₂ after 1/1/2023	
Air cooled (cooling mode)	≥65,000 Btu/h and <135,000 Btu/h	Electric resistance (or none)	Split system and single package	11.0 EER before 1/1/2023 12.2 IEER before 1/1/2023 14.1 IEER after 1/1/2023	AHRI 340/360
				10.8 EER before 1/1/2023 12.0 IEER before 1/1/2023 13.9 IEER after 1/1/2023	
	>135,000 Btu/h	Electric		10.6 EER	

Equipment Classification

Rating conditions corresponding to the listed minimum efficiency

Minimum efficiency; if multiple criteria are provided (e.g., EER + IEER), both must be met

90.1 Mandatory Requirements Ceiling Fans (Section 6.4.1.3)

- Large-diameter ceiling fans shall be rated in accordance with 10 CFR 430 Appendix U or AMCA 230. The following data shall be provided
 - Blade span (blade tip diameter)
 - Rated airflow and power consumption at the maximum speed
- The data provided shall meet one of the following requirements:
 - It is determined by an independent laboratory.
 - It is included in a database published by USDOE.
 - It is certified under a program meeting the requirements of Section 6.4.1.5.

Exception to 6.4.1.3.1

Ceiling fans not covered in the scope of 10 CFR Part 430.

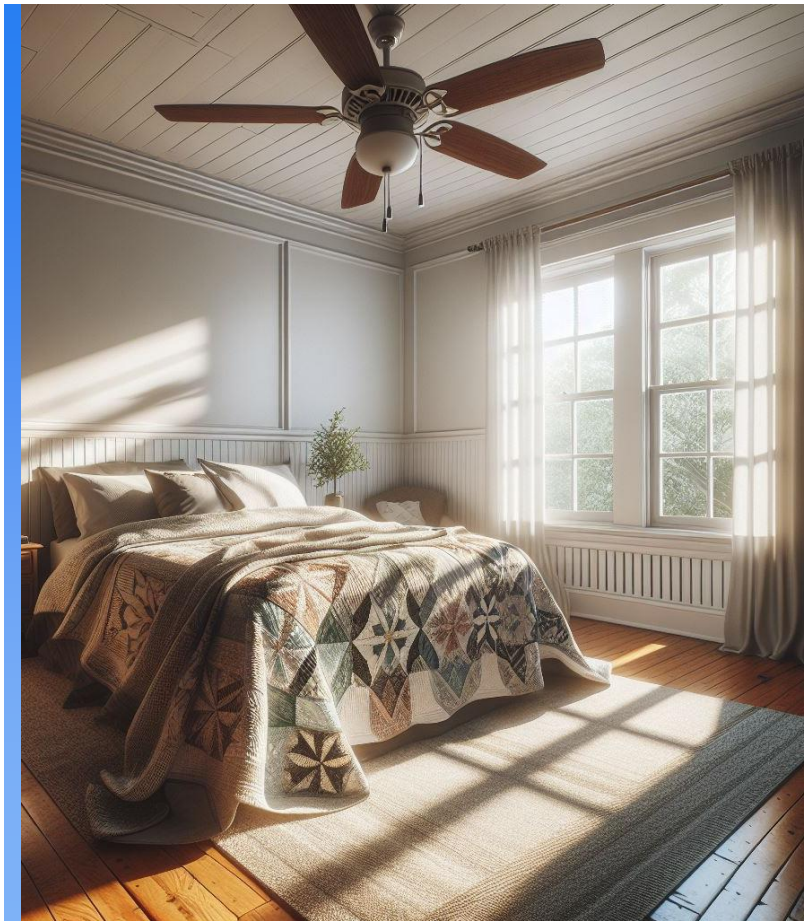

90.1 Mandatory Requirements Zone Thermostatic Controls

Zone thermostatic controls must respond to temperature within the zone and have provisions to eliminate or minimize simultaneous heating & cooling (6.4.3.1 & 6.4.3.2)

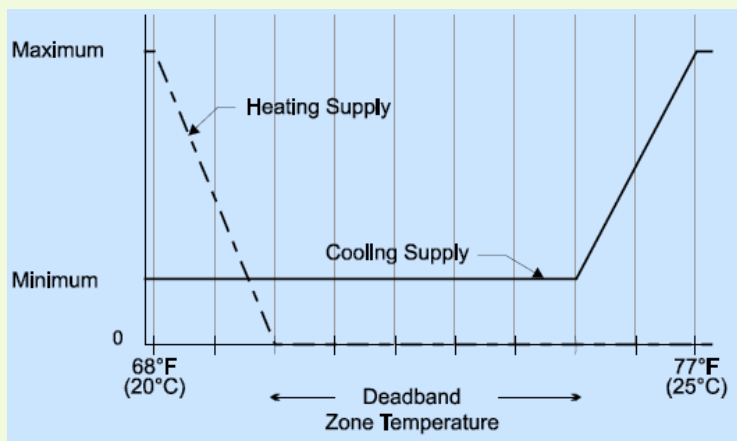

SAMPLE DEADBAND THERMOSTATIC CONTROL*

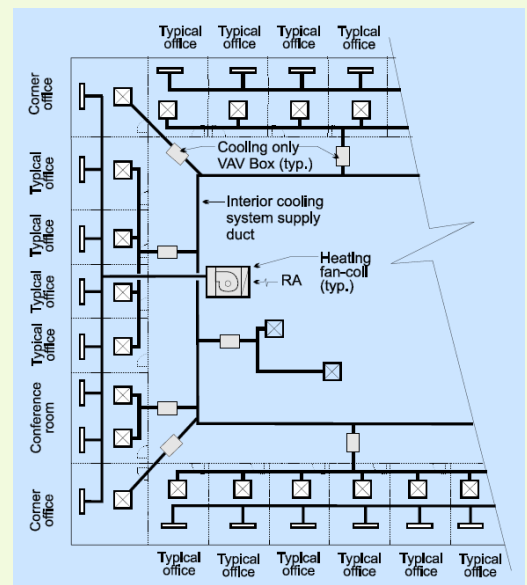

PERIMETER/CORE SYSTEM EXAMPLE*

90.1 Mandatory Requirements Off-Hour Controls

- Automatic shutdown (6.4.3.3.1)
 - Time switch or scheduling controls
 - Occupant sensor
 - Manually operated timer
 - Interlock to a security system
- Setback controls (6.4.3.2.2)
- Optimum start controls (6.4.3.3.3)
- Zone isolation (6.4.3.3.4)
- Automatic Control of HVAC in Hotel/Motel Guest Rooms (6.4.3.3.5)
 - Setpoint and ventilation controls required



90.1 Mandatory Requirements Motorized Dampers

- Motorized dampers for stairs and elevator shaft vents (6.4.3.4.1)
- Motorized dampers on the outdoor air intake and exhaust systems to facilitate automatic shut off when system or space are not in use (6.4.3.4.2)
- Maximum allowed damper leakage (6.4.3.4.3)

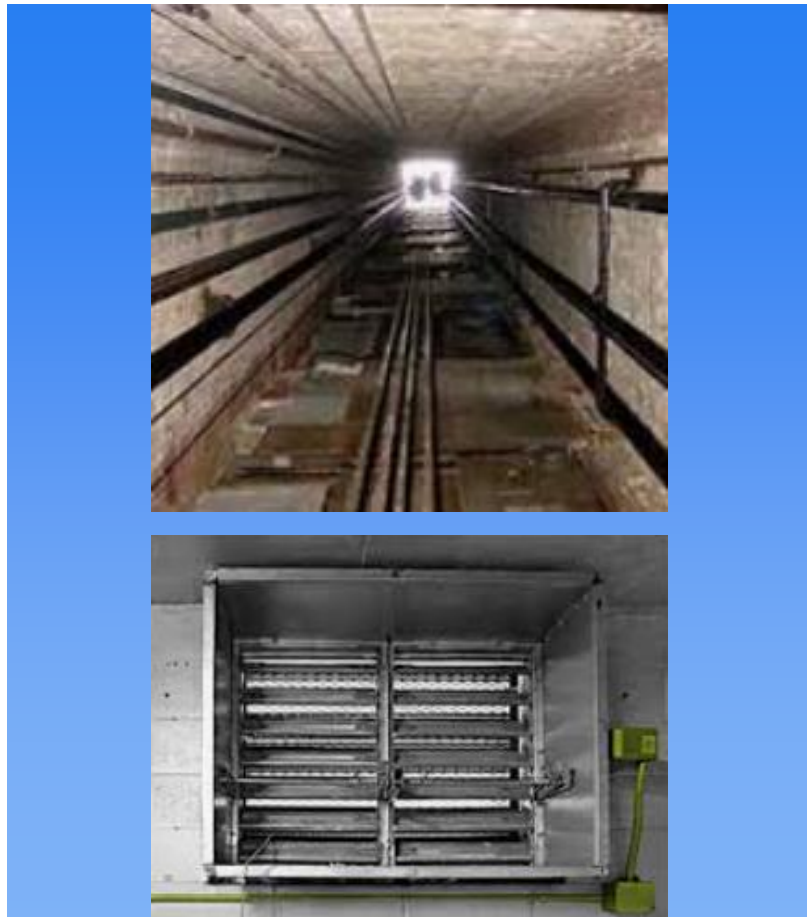

90.1 Mandatory Requirements Ventilation System Controls

- Automatic controls to shut off fans when not required (6.4.3.4.4)
- Garage ventilation capable to automatically stage fans or modulate airflow rates to 50% or less of design capacity based on contaminant levels (6.4.3.4.5)
- Demand control ventilation for spaces over 500 ft² with design occupancy equal or greater than 25 people per 1000 ft² (6.4.3.8)



90.1 Mandatory Requirements Other Controls

- Heat pump auxiliary heat controls to avoid supplemental electric resistance heating when the heating load can be met by the heat pump alone (6.4.3.5)
- Humidity controls to avoid use of fossil fuel or electricity to achieve relative humidity above 30% in the warmest zone served by humidification system or below 60% in the coldest zone served by dehumidification system. (6.4.3.6)
- Automatic controls on freeze protection and snow/ice melt system based on outdoor air temperature, pavement temperature and precipitations (6.4.3.7)
- Temperature controls in heated or cooled vestibules limiting setpoints and requiring shutting off heating when outdoor temperature is above 45F (6.4.3.9)
- Direct Digital Controls (DDC) for most systems in new buildings and for many alternations and additions (6.4.3.10)

90.1 Other Mandatory Requirements

- Diagnostic
 - Chilled water plant monitoring to measure electricity use and *efficiency* with trend information collected at 15-minute timestep and hourly, daily, monthly and annual data graphically displayed and stored for at least 36 months (6.4.3.11)
 - Economizer fault detection and diagnostics, including but not limited to permanently installed outdoor air, supply air and return air (if applicable) temperature sensors to monitor system operation, system status indicators, and automatic fault detection and reporting to DDC system (6.4.3.12)
- Duct and plenum insulation and leakage, piping insulation
- Requirements for walk-in coolers and freezers (6.4.5)
- Requirements for the refrigerated display cases (6.4.6)
- Rating requirements for liquid-to-liquid heat exchangers (6.4.7)
- Heating and cooling design load and pump head calculation requirements (6.4.2)

Other MA Stretch 2023 Mandatory Requirements

Code Requirements Other Than Envelope	Relative Performance
C401.4.1 Partial Space Heating Electrification	Yes, if highly ventilated
C401.4.2 Full Space Heating Electrification	Yes, for high glazed wall system buildings (C402.1.5.2); only if not highly ventilated
C403 Building Mechanical Systems	No except must meet C403.5 (Economizer) and C403.7 (Ventilation and exhaust systems)

(Reminder from 4-Hour Training)

HVAC: Proposed Design

Modeling Proposed HVAC

HVAC systems in the proposed design must be modeled as designed, reflecting the actual system type, capacity, efficiency, controls and ancillary features such as economizer and exhaust air energy recovery.

Exception: All conditioned spaces must be simulated as being both heated and cooled even if no cooling or heating systems are specified.

- Where no heating system exists or is specified, the same heating system type must be modeled in the proposed design as in the baseline design, and the modeled systems shall comply with but not exceed the requirements of Section 6.
- Where no cooling system exists or is specified, the same cooling system type must be modeled in the proposed design as in the baseline design, and the modeled systems shall comply with but not exceed the requirements of Section 6.

Same system type as in the baseline building design, except no cooling must be modeled in *spaces* designed with heating only *systems* serving storage rooms, stairwells, vestibules, electrical/mechanical rooms, and restrooms not exhausting or transferring air from mechanically cooled thermal zones in the *proposed design*

Modeling Proposed HVAC



HVAC systems in the proposed design must be modeled as designed, reflecting the actual system type, capacity, efficiency, controls and ancillary features such as economizer and exhaust air energy recovery.

Exception: All conditioned spaces must be simulated as being both heated and cooled even if no cooling or heating systems are specified.

- Where no heating system exists or is specified, the same heating system type must be modeled in the proposed design as in the baseline design, and the modeled systems shall comply with but not exceed the requirements of Section 6.
- Where no cooling system exists or is specified, the same cooling system type must be modeled in the proposed design as in the baseline design, and the modeled systems shall comply with but not exceed the requirements of Section 6.

Exception: no cooling must be modeled in *spaces* designed with heating only *systems* serving storage rooms, stairwells, vestibules, electrical/mechanical rooms, and restrooms not exhausting or transferring air from mechanically cooled thermal zones in the *proposed design*.

Relative Performance – Proposed

Extracting Fan Power from Efficiency SEER and HSPF

If the HVAC system efficiency for the proposed design is given as SEER or HSPF and the EER or COP ratings are not available from the manufacturer, the equivalent system efficiency excluding fan power must be calculated using the following relationships, based on 90.1 Section 11.5.2 (c):

Equation 1: $COP_{nfcooling} = -0.0076 \times SEER^2 + 0.3796 \times SEER$

Equation 2: $COP_{nfheating} = -0.0296 \times HSPF^2 + 0.7134 \times HSPF$

Where: $COP_{nfcooling/heating}$ = Coefficient of Performance (COP) cooling/heating efficiency excluding AHRI rating fan power

Relative Performance – Proposed

Extracting Fan Power from Efficiency

EER

Based on Appendix G section G3.1.2.1, where efficiency ratings, such as EER and COP, include fan energy, the descriptor must be broken down into its components so that supply fan energy can be modeled separately. Manufacturers often publish both gross and net AHRI capacities, and the difference between these two figures is equal to the fan power. The following calculation must be used to extract fan power from the rated efficiency of the specified equipment:

Equation 3:

$$EER_{ADJ} = \frac{Q_{T,RATED} + BHP_{SUPPLY} * 2.545}{\frac{Q_{T,RATED}}{EER} - BHP_{SUPPLY} * .7457}$$

Where:

EER_{ADJ} = the adjusted Energy Efficiency Ratio with fan power removed, to be used for simulation purposes

EER = the rated Energy Efficiency Ratio, at AHRI conditions

$Q_{T,RATED}$ = the AHRI rated total cooling capacity of the unit (net capacity) in kBtu/h

BHP_{SUPPLY} = the supply fan brake horsepower (bhp) at AHRI rating conditions. For the purposes of these calculations, BHP includes losses of the fan motor and drive.

Relative Performance – Proposed

Extracting Fan Power from Efficiency

EER

For heat pumps, the following equation should be used for extracting supply fan power from heating COP when AHRI supply fan BHP is available:

Equation 4:

$$COP_{ADJ} = \frac{Q_{T,RATED} - BHP_{SUPPLY} * 2.545}{\frac{Q_{T,RATED}}{COP} - BHP_{SUPPLY} * 2.545}$$

Where:

COP_{ADJ} = the adjusted COP with fan power removed, to be used for simulation purposes

COP = the rated COP, at ARI conditions

$Q_{T,RATED}$ = the ARI rated total heating capacity of the unit (net capacity) in kBtu/h

BHP_{SUPPLY} = the supply fan brake horsepower (bhp) at AHRI rating conditions. For the purposes of these calculations, BHP includes losses of the fan motor and drive.

If the AHRI supply fan BHP is not available from the manufacturer, then fan power must be extracted from the proposed systems using 90.1 11.5.2 (c) for the analogous system type.

Relative Performance – Proposed

Extracting Fan Power Example

Question: A 10,000 ft² office building has three thermal blocks, each served by a packaged heat pump. Each unit is identical and has the following design specifications:

- Supply flow of 4,500 CFM
- AHRI net cooling capacity 144,000 btu/h
- 11.5 EER
- Gross cooling capacity at AHRI is 151,000 btu/h
- Supply and return fan BHP at design conditions for each unit are 2.8 and 1.1, respectively.
- Flow rate across the return fan is 90% of supply flow.
- Each thermal block also includes a restroom with a 200 CFM continuously running exhaust fan with a 75W motor (~1/10 HP).

What should be the cooling efficiency modeled in the proposed design model?

Relative Performance – Proposed

Extracting Fan Power Example

Answer: To extract proposed fan power, use Equation 3 from the guidelines. For BHP_{SUPPLY} , take the difference between gross and net cooling capacities and convert to HP:

$$\frac{(151,000 \text{ Btuh} - 144,000 \text{ Btuh}) / (1000 \text{ Btuh/kBtuh} * 3.412 \text{ kBtu/kWh} * 0.746)}{2.75 \text{ BHP}}$$

$$EER_{adj} = \frac{144 + 2.75 * 2.545}{11.5 - 2.75 * .7457} = \frac{151}{10.47} = 14.4$$

Equation 3:

$$EER_{ADJ} = \frac{Q_{T,RATED} + BHP_{SUPPLY} * 2.545}{\frac{Q_{T,RATED}}{EER} - BHP_{SUPPLY} * .7457}$$

Relative Performance – Proposed

Question: A 10,000 ft² office building has three thermal blocks, each served by a packaged heat pump. Each unit is identical and has the following design specifications:

- Supply flow of 4,500 CFM,
- AHRI net cooling capacity 144,000 btu/h,
- 11.5 EER
- Gross cooling capacity at AHRI is 151,000 btu/h
- Supply and return fan BHP at design conditions for each unit are 2.8 and 1.1 respectively.
- Flow rate across the return fan is 90% of supply flow.
- Each thermal block also includes a restroom with a 200 CFM continuously running exhaust fan with a 75W motor (~1/10 HP).

What should be the cooling efficiency modeled in the proposed design model?



Sample Data Sheet

General Data

Table 2. General data - 6 to 10 tons with eFlex™ and eDrive™ technology (208/230 volt)

	6 Tons	7.5 Tons	8.5 Tons	10 Tons
	T/YZC072F3	T/YZC090F3	T/YZC102F3	T/YZC120F3
Cooling Performance^(A)				
Gross Cooling Capacity - Full Load	71,000	92,000	103,000	117,000
EER/IEER ^(B)	12.8/23.2	12.8/22.4	12.6/22.5	12.1/23.0
Nominal cfm/AHRI Rated cfm	2,400/2,400	3,000/2,850	3,400/2,975	4,000/4,000
AHRI Net Cooling Capacity - Full Load	70,000	90,000	99,000	114,000
System Power (kW)	5.47	7.03	7.86	9.42

Quiz #26

Extracting Fan Energy from Efficiency

Question: A packaged HVAC unit has a rated DX cooling efficiency of 12.2 EER, select the efficiency that the project team likely calculated when removing fan energy from the rated efficiency.

- A. 13.5 EER
- B. 12.0 EER
- C. 11.5 EER
- D. 10.0 EER

Relative Performance –Proposed

Quiz #26

Extracting Fan Energy from Efficiency

Question: A packaged HVAC unit has a rated DX cooling efficiency of 12.2 EER, select the efficiency that the project team likely calculated when removing fan energy from the rated efficiency.

- A. 13.5 EER (the efficiency is going to be higher with fan energy removed)
- B. 12.0 EER
- C. 11.5 EER
- D. 10.0 EER

Relative Performance –Proposed

Mechanical Ventilation

Mechanical ventilation must be modeled as specified, including ventilation delivery method such as via the space conditioning system or a Dedicated Outdoor Air System (DOAS), ventilation controls such as Demand Control Ventilation (DCV), and exhaust air energy recovery.

90.1 Section 6.4.2.4 includes mandatory requirements for ventilation system controls that must be met by the ventilation system design. Below are several common examples:

- Automatic controls to shut off fans when outdoor air not required (6.4.3.4.4)
- Garage ventilation capable to automatically stage fans or modulate airflow rates to 50% or less of design capacity based on contaminant levels (6.4.3.4.5)
- DCV for spaces over 500 ft² with design occupancy equal or greater than 25 people per 1000 ft² (6.4.3.8). If the occupant density in spaces that are typically subject to the DCV requirement is less than the default occupant density listed in ASHRAE 62.1 Table 6-1, making DCV not required, the source for the assumed occupant density must be documented.

Relative Performance – Proposed

Fan System Operation

Fan systems that provide outside air to the building must operate continuously whenever the building is occupied, and cycle on and off to maintain the setback temperature when the building is unoccupied, per 90.1 G3.1.2.4 and Table G3.1 #4. In unoccupied mode, outside air must not be provided unless required by applicable health and safety mandated minimum ventilation requirements.

Relative Performance – Proposed

Chiller Performance Curves

Construction documents provide (Full Load) FL and IPLV (Integrated Part Load Value) of the specified equipment. Commonly used simulation tools allow entering chiller full load efficiency and performance curves that determine chiller operation at lower loads, but do not the IPLV input.

[90.1 2019 addendum bd](#) requires that where the performance curves for the chillers specified in the proposed design are not available, the provided default performance curves are used based on the specified chiller type.

The addendum also prescribes chiller minimum part-load ratio (ratio of load to available capacity at a given simulation time step) and minimum compressor unloading ratio (part-load ratio below which the chiller capacity cannot be reduced by unloading and chiller is false loaded) of 0.25.

Relative Performance – Proposed

Boiler Performance Curves



Condensing boiler performance is dependent on return water temperature and variations in load..

For projects with boiler system(s) in the proposed design, modeling parameters must reflect mechanical drawings. Design supply and return water temperatures must be explicitly entered into the simulation tool if the tool can automatically capture their impact on boiler efficiency through performance curves. If the tool is not capable of automatically adjusting efficiency based on entered loop temperatures (such as TRACE 700), efficiency input must be adjusted manually to reflect manufacturer's performance data for the boiler at actual operating conditions.

Either the default performance curves included in Annex B of the guidelines or the actual performance curves for the specified boilers should be used.

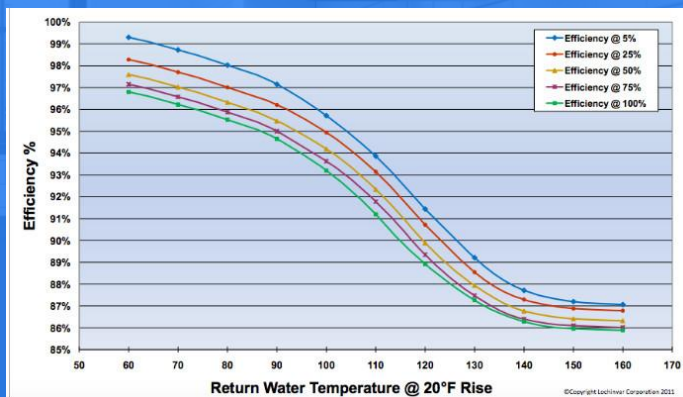

Lochinvar Corporation Boiler Efficiency

Relative Performance – Proposed

HVAC: Baseline Design

HVAC System Type

90.1 2019 addendum ab clarified and streamlined the process of determining the baseline HVAC system types. These updated requirements must be followed when documenting compliance with Section C407.2. Below is a summary of the process based on amended Section G3.1.1.1:

1. Determine the combined gross conditioned and semi-heated floor area for each of the following building area types in the proposed design:
 - Residential and residential-associated zones
 - Public assembly
 - Heating-only storage
 - Retail
 - Hospitals
 - Other nonresidential

HVAC System Type



90.1 2019 addendum ab clarified and streamlined the process of determining the baseline HVAC system types. These updated requirements must be followed when documenting compliance with Section C407.2. Below is a summary of the process based on amended Section G3.1.1.1:

1. Determine the combined gross conditioned and semi-heated floor area for each of the following building area types in the proposed design:

- Residential and residential-associated zones
- Public assembly
- Heating-only storage
- Retail
- Hospitals
- Other nonresidential

Residential associated HVAC zone: any HVAC zone that primarily includes nonresidential spaces designed to serve occupants of residential spaces, including but not limited to corridors, stairwells, elevator lobbies, and common restrooms, on a floor where over 75% of the gross conditioned floor area are residential spaces. This definition does not apply to HVAC zones within hospitals.

Relative Performance – Baseline

HVAC System Type Continued



2. Classify the nonresidential building area type with the largest combined area as the predominant nonresidential building area type. Add the combined area of any remaining nonresidential building area types with less than 20,000 ft² to the combined area of the predominant nonresidential building area type.

3. Select a baseline HVAC system type from Table G3.1.1-3 for each of the following building area types included in the proposed design: 1. Residential + residential associated 2. Predominant nonresidential 3. Each additional nonresidential building area type with more than 20,000 ft² of combined area based on G3.1.1.1.

Table G3.1.1-3 Baseline HVAC System Types

Building Area Types ^a , Number of Stories ^b , and Combined Floor Area ^c	Climate Zones 3B, 3C, and 4 to 8	Climate Zone
Residential	System 1—PTAC	System 1
Public assembly area smaller than 120,000 ft ²	System 3—PSZ-AC	System 3
Public assembly area equal to or larger than 120,000 ft ²	System 12—SZ-CV-HW	System 12
Heated-only storage	System 9—Heating and ventilation	System 9
Retail in a building that is 1 or 2 stories	System 3—PSZ-AC	System 3
Hospital that is either • larger than 150,000 ft ² or • in a building greater than 5 stories.	System 7—VAV with reheat	System 7
Hospital—all other	System 5—Packaged VAV with reheat	System 5
Other Nonresidential area that is both • smaller than 25,000 ft ² and • in a building 3 stories or fewer.	System 3—PSZ-AC	System 3
Other Nonresidential area that is both • smaller than 25,000 ft ² and • in a building with 4 or 5 stories.	System 5—Packaged VAV with reheat	System 5
Other Nonresidential area that is both • 25,000 ft ² to 150,000 ft ² and • in a building that is 5 stories or fewer.	System 5—Packaged VAV with reheat	System 5
Other Nonresidential area that is either • larger than 150,000 ft ² or • in a building greater than 5 stories.	System 7—VAV with reheat	System 7

a. Building area type determined in accordance with Section G3.2.1.1.
 b. The total number of stories in a building, including above-grade and below-grade stories but not including stories solely devoted to parking.
 c. Combined gross conditioned floor area and semiheated floor area, of the building area type, based on the requirements of Section G3.2.1.1.

The amended section G3.1.1.2 includes requirements for determining additional and adjusted baseline HVAC System Types

Relative Performance – Baseline

HVAC System Type Continued



G3.1.1.2 f Residential associated HVAC zones shall use system type 3 or 4 based on climate zone.

Table G3.1.1-3 Baseline HVAC System Types

Building Area Types ^a , Number of Stories ^b , and Combined Floor Area ^c	Climate Zones 3B, 3C, and 4 to 8	Climate Zone
Residential	System 1—PTAC	System 1
Public assembly area smaller than 120,000 ft ²	System 3—PSZ-AC	System 3
Public assembly area equal to or larger than 120,000 ft ²	System 12—SZ-CV-HW	System 12
Heated-only storage	System 9—Heating and ventilation	System 10
Retail in a building that is 1 or 2 stories	System 3—PSZ-AC	System 3
Hospital that is either • larger than 150,000 ft ² or • in a building greater than 5 stories.	System 7—VAV with reheat	System 7
Hospital—all other	System 5—Packaged VAV with reheat	System 5
Other Nonresidential area that is both • smaller than 25,000 ft ² and • in a building 3 stories or fewer.	System 3—PSZ-AC	System 3
Other Nonresidential area that is both • smaller than 25,000 ft ² and • in a building with 4 or 5 stories.	System 5—Packaged VAV with reheat	System 6
Other nonresidential area that is both • 25,000 ft ² to 150,000 ft ² and • in a building that is 5 stories or fewer.	System 5—Packaged VAV with reheat	System 6
Other Nonresidential area that is either • larger than 150,000 ft ² or • in a building greater than 5 stories.	System 7—VAV with reheat	System 8

a. Building area type determined in accordance with Section G3.2.1.1.
 b. The total number of stories in a building, including above-grade and below-grade stories but not including stories solely devoted to parking.
 c. Combined gross conditioned floor area and semih conditioned floor area, of the building area type, based on the requirements of Section G3.2.1.1.

Relative Performance – Baseline

HVAC System Type Selection Example

Question: A new construction project involves a 5 story 100,000 ft² building with a retail store on the first floor (25,000 ft²) and a hotel on floors 2-5. The retail store includes a sales floor, offices, restrooms and a heated-only storage space. Hotel floors include guest rooms, corridors, heated only stairwells, conference rooms and management offices. What HVAC systems should be modeled in the baseline?

Table G3.1.1-3 Baseline HVAC System Types

Building Area Types ^a , Number of Stories ^b , and Combined Floor Area ^c	Climate Zones 3B, 3C, and 4 to 8	Climate Zone
Residential	System 1—PTAC	System 1
Public assembly area smaller than 120,000 ft ²	System 3—PSZ-AC	System 3
Public assembly area equal to or larger than 120,000 ft ²	System 12—SZ-CV-HW	System 12
Heated-only storage	System 9—Heating and ventilation	System 10
Retail in a building that is 1 or 2 stories	System 3—PSZ-AC	System 3
Hospital that is either • larger than 150,000 ft ² or • in a building greater than 5 stories.	System 7—VAV with reheat	System 7
Hospital—all other	System 5—Packaged VAV with reheat	System 5
Other Nonresidential area that is both • smaller than 25,000 ft ² and • in a building 3 stories or fewer.	System 3—PSZ-AC	System 3
Other Nonresidential area that is both • smaller than 25,000 ft ² and • in a building with 4 or 5 stories.	System 5—Packaged VAV with reheat	System 6
Other nonresidential area that is both • 25,000 ft ² to 150,000 ft ² and • in a building that is 5 stories or fewer.	System 5—Packaged VAV with reheat	System 6
Other Nonresidential area that is either • larger than 150,000 ft ² or • in a building greater than 5 stories.	System 7—VAV with reheat	System 8

a. Building area type determined in accordance with Section G3.2.1.1.
 b. The total number of stories in a building, including above-grade and below-grade stories but not including stories solely devoted to parking.
 c. Combined gross conditioned floor area and semih conditioned floor area, of the building area type, based on the requirements of Section G3.2.1.1.

Relative Performance – Baseline

HVAC System Type Selection Example



Answer:

Determine the baseline HVAC system types based on building area types following 90.1 addendum ab Section G3.1.1.1

Building is 5 stories & 100,000 ft²

Based on 90.1 2019 Addendum ab definition, any HVAC zone that primarily includes nonresidential spaces designed to serve occupants of residential spaces on a floor where over 75% of the gross conditioned floor area are residential spaces is considered residential-associated. On floors 2-5, hotel guest rooms account for more than 75% of conditioned and semi heated floor area, and all non-residential spaces on these floors are used for the hotel function. Thus, the residential zones on floors 2-5 shall be modeled with baseline System 1 – PTAC following Table G3.1.1-3 and the residential associated spaces on these floors shall be modeled with System 3 – PSZ- AC following 9.1-2019 Addendum ab G3.1.1.2 (f).

The entire area of the first floor is considered retail and would map to baseline System 5 – Packaged VAV with reheat following Table G3.1.1-3 based on the number of floors of the entire building and ft².

Building Area Types ^a , Number of Stories ^b , and Combined Floor Area ^c	Climate Zones 3B, 3C, and 4 to 8	Climate Zone 9
Residential	System 1—PTAC	System 1—PTAC
Public assembly area smaller than 120,000 ft ²	System 3—PSZ-AC	System 3—PSZ-AC
Public assembly area equal to or larger than 120,000 ft ²	System 12—SZ-CV-HW	System 12—SZ-CV-HW
Heated-only storage	System 9—Heating and ventilation	System 10—Heating and ventilation
Retail in a building that is 1 or 2 stories	System 3—PSZ-AC	System 3—PSZ-AC
Hospital that is either <ul style="list-style-type: none"> larger than 150,000 ft² or in a building greater than 5 stories. 	System 7—VAV with reheat	System 7—VAV with reheat
Hospital—all other	System 5—Packaged VAV with reheat	System 5—Packaged VAV with reheat
Other Nonresidential area that is both <ul style="list-style-type: none"> smaller than 25,000 ft² and in a building 3 stories or fewer. 	System 3—PSZ-AC	System 3—PSZ-AC
Other Nonresidential area that is both <ul style="list-style-type: none"> smaller than 25,000 ft² and in a building with 4 or 5 stories. 	System 5—Packaged VAV with reheat	System 6—Packaged VAV with reheat
Other nonresidential area that is both <ul style="list-style-type: none"> 25,000 ft² to 150,000 ft² and in a building that is 5 stories or fewer. 	System 5—Packaged VAV with reheat	System 6—Packaged VAV with reheat
Other Nonresidential area that is either <ul style="list-style-type: none"> larger than 150,000 ft² or in a building greater than 5 stories. 	System 7—VAV with reheat	System 7—VAV with reheat

a. Building area type determined in accordance with Section G3.2.1.1.
 b. The total number of stories in a building, including above-grade and below-grade stories but not including stories solely devoted to parking.
 c. Combined gross conditioned floor area and semiheated floor area, of the building area type, based on the requirements of Section G3.2.1.1.

Relative Performance – Baseline

HVAC System Type Selection Example



Answer:

Determine additional and adjusted baseline HVAC system types following 90.1 addendum ab Section G3.1.1.2

Heated only stairwells on the hotel floors and heated only storage on the retail floor are subject to addendum ab Section G3.1.1.2 Exception (c) and will be modeled with System 9 – Heating and Ventilation.

HVAC zones designed with heating-only systems in the proposed design serving storage rooms, stairwells, vestibules, electrical/mechanical rooms, and restrooms not exhausting or transferring air from mechanically cooled thermal zones in the proposed design shall use system type 9 or 10 in the baseline building design.

Relative Performance – Baseline

HVAC Efficiency

Table G3.5.1 Performance Rating Method Air Conditioners (efficiency ratings excluding supply fan power)

Equipment Type	Size Category	Heating Section Type	Subcategory or Rating Condition	Efficiency	Test Procedure
Air conditioners, air-cooled	<65,000 Btu/h	All	Single-package	3.0 COP _{ntcooling}	AHRI 210/240
	>65,000 Btu/h and <135,000 Btu/h		Split-system and single-package	3.5 COP _{ntcooling}	AHRI 340/360
	>135,000 Btu/h and <240,000 Btu/h	3.4 COP _{ntcooling}			
	>240,000 Btu/h and <760,000 Btu/h	3.5 COP _{ntcooling}			
	>760,000 Btu/h	3.6 COP _{ntcooling}			

Table G3.5.2 Performance Rating Method Electrically Operated Unitary and Applied Heat Pumps—Minimum Efficiency Requirements (efficiency ratings excluding supply fan power)

Equipment Type	Size Category	Heating Section Type	Subcategory or Rating Condition	Minimum Efficiency	Test Procedure
Air-cooled (cooling mode)	<65,000 Btu/h	All	Single package	3.0 COP _{ntcooling}	AHRI 210/240
	>65,000 Btu/h and <135,000 Btu/h		Split-system and single-package	3.4 COP _{ntcooling}	AHRI 340/360
	>135,000 Btu/h and <240,000 Btu/h	3.2 COP _{ntcooling}			
	>240,000 Btu/h	3.1 COP _{ntcooling}			
Air-cooled (heating mode)	<65,000 Btu/h (cooling capacity)		Single-package	3.4 COP _{ntcooling}	AHRI 210/240
	>65,000 Btu/h and <135,000 Btu/h (cooling capacity)		47°F db/43°F wb outdoor air	3.4 COP _{ntcooling}	AHRI 340/360
		17°F db/15°F wb outdoor air	2.3 COP _{ntcooling}		
		47°F db/43°F wb outdoor air	3.4 COP _{ntcooling}	2.1 COP _{ntcooling}	
		17°F db/15°F wb outdoor air	2.1 COP _{ntcooling}		

- Baseline air-side HVAC system efficiency (COP_{NFCOOLING} and COP_{NFHEATING}) is determined based on 90.1 Tables G3.5.1, G3.5.2, G3.5.4, and G3.5.5.
- The values provided in the tables depend on the baseline system capacity which must be determined using the simulation sizing runs following Section G3.1.2.2.1.
- Table G3.1 #7-9 allow modeling multiple HVAC zones that meet the specified criteria as a single thermal block to simplify modeling. To avoid impact of these modeling simplifications on the baseline system efficiency, the baseline efficiencies must be based on the load of individual HVAC zones prior to aggregation into thermal blocks as is allowed in 90.1 Table G3.1 #7 Thermal Blocks – HVAC Zones Designed. When identical floors are grouped in accordance with Section G3.1.1(a)(4), efficiencies in G3.5.1 for the Baseline HVAC System Types 5 or 6 must be based on the cooling equipment capacity of equipment serving a single floor.

Relative Performance – Baseline

Quiz #27

Question: What baseline cooling efficiency should be modeled for a 950,000 Btu/h capacity system 3 unit in which 5 HVAC zones were aggregated to form the thermal block that this system serves in the baseline?

- 3.1 COP_{ntcooling}
- 3.6 COP_{ntcooling}
- 3.4 COP_{ntcooling}
- 2.1 COP_{ntcooling}

Relative Performance – Baseline

Table G3.5.1 Performance Rating Method Air Conditioners (efficiency ratings excluding supply fan power)

Equipment Type	Size Category	Heating Section Type	Subcategory or Rating Condition	Efficiency	Test Procedure
Air conditioners, air-cooled	<65,000 Btu/h	All	Single-package	3.0 COP _{ntcooling}	AHRI 210/240
	>65,000 Btu/h and <135,000 Btu/h		Split-system and single-package	3.5 COP _{ntcooling}	AHRI 340/360
	>135,000 Btu/h and <240,000 Btu/h	3.4 COP _{ntcooling}			
	>240,000 Btu/h and <760,000 Btu/h	3.5 COP _{ntcooling}			
	>760,000 Btu/h	3.6 COP _{ntcooling}			

Table G3.5.2 Performance Rating Method Electrically Operated Unitary and Applied Heat Pumps—Minimum Efficiency Requirements (efficiency ratings excluding supply fan power)

Equipment Type	Size Category	Heating Section Type	Subcategory or Rating Condition	Minimum Efficiency	Test Procedure
Air-cooled (cooling mode)	<65,000 Btu/h	All	Single package	3.0 COP _{ntcooling}	AHRI 210/240
	>65,000 Btu/h and <135,000 Btu/h		Split-system and single-package	3.4 COP _{ntcooling}	AHRI 340/360
	>135,000 Btu/h and <240,000 Btu/h	3.2 COP _{ntcooling}			
	>240,000 Btu/h	3.1 COP _{ntcooling}			
Air-cooled (heating mode)	<65,000 Btu/h (cooling capacity)		Single-package	3.4 COP _{ntcooling}	AHRI 210/240
	>65,000 Btu/h and <135,000 Btu/h (cooling capacity)		47°F db/43°F wb outdoor air	3.4 COP _{ntcooling}	AHRI 340/360
		17°F db/15°F wb outdoor air	2.3 COP _{ntcooling}		
		47°F db/43°F wb outdoor air	3.4 COP _{ntcooling}	2.1 COP _{ntcooling}	
		17°F db/15°F wb outdoor air	2.1 COP _{ntcooling}		

Quiz #27

Answer: C Consult Table G3.5.1 and determine the efficiency to model based on the capacity. Because the thermal block that the unit serves includes 5 aggregated HVAC zones the capacity needs to be divided by the # of zones.

950,000 Btuh/5 thermal zones = 190,000 Btuh → 3.4 COP_{nfc}

Table G3.5.1 Performance Rating Method Air Conditioners (efficiency ratings excluding supply fan power)

Equipment Type	Size Category	Heating Section Type	Subcategory or Rating Condition	Efficiency	Test Procedure
Air conditioners, air-cooled	<65,000 Btu/h	All	Single-package	3.0 COP_{nfc}	AHRI 210/240
	≥65,000 Btu/h and <135,000 Btu/h		Split-system and single-package	3.5 COP_{nfc}	AHRI 340/360
	≥135,000 Btu/h and <240,000 Btu/h			3.4 COP_{nfc}	
	≥240,000 Btu/h and <760,000 Btu/h			3.5 COP_{nfc}	
	≥760,000 Btu/h			3.6 COP_{nfc}	

Relative Performance – Baseline

Ventilation



As a general rule, the minimum outdoor air ventilation rate must be modeled the same in the baseline design as in the proposed design except when the following conditions apply:

- Following 90.1 Section G3.1.2.6 exception (c), if the minimum outdoor air intake flow in the proposed design exceeds the amount required by the applicable code, then the baseline building design must be modeled to reflect the minimum required ventilation rate and will be less than in the proposed design. There is no over-ventilation penalty for healthcare facilities following ventilation requirements of ASHRAE Standard 170, as Section 7 of the standard allows higher rates if deemed necessary by the owner.
- Zones with air distribution effectiveness $E_z > 1.0$ may be modeled with a lower ventilation rate in the proposed design compared to the baseline as described in 90.1 Section G3.1.2.5 Exception (2). This performance credit may apply to designs with displacement ventilation or other techniques that result in ventilation effectiveness greater than 1.0. Projects must use the Ventilation Rate Procedures described in ASHRAE Standard 62.1, Section 6.2 to demonstrate the savings.
- Following Section G3.1.2.5 Exception (4), baseline systems serving only laboratory spaces that are prohibited from recirculating return air by code or accreditation standards must be modeled with 100% OA in the baseline. This may result in higher ventilation rates in the baseline compared to the proposed design.

Relative Performance – Baseline

Fan Systems



The system baseline fan power must be calculated according to Appendix G section G3.1.2.9 and represents the total fan power allowance including supply, return, and exhaust fans, central and zonal.

Baseline fan power allowance must be allocated to supply, return and exhaust in the same proportion as in the proposed design.

Baseline fan power allowance may be increased to account for air filtration (based on MERV rating) and sound attenuation when specified for the proposed design. Exhaust air energy recovery adjustment may be used only when energy recovery is modeled in the baseline. Fully ducted return adjustment may only be used when the proposed design is required by code or accreditation standards to be fully ducted is required by applicable code

The often preferred method for modeling baseline fan power is by specifying Watt per CFM of air flow in the model, as this avoids the need to adjust fan power whenever flow rates change when evaluating ECMs. However, if a software tool does not allow inputting power per unit flow, the same purpose can be achieved by defining the total static pressure drop (TSP) and overall fan efficiency fraction (including motor, drive, and mechanical efficiencies). If TSP and/or overall fan efficiency are unknown, use Equation 5 to convert from kW/cfm (power per unit flow).

Relative Performance – Baseline

Fan Systems Continued

Equation 5

$$Power_{kW/CFM} = \frac{TSP_{in.wg}}{8520 \times \eta_{overall}}$$

If overall fan efficiency fraction $\eta_{overall}$ is unknown, 0.55 default may be used. The accuracy of this estimate does not affect the results of the simulation, since adjusting the efficiency fraction when using Eq. 5 will cause an offsetting adjustment in the total static pressure.

Relative Performance – Baseline

Fan Power Example

Question: A 10,000 ft² 1-story office building has three thermal blocks, each served by a packaged heat pump. Each unit is identical has a fully ducted return, MERV 13 filters, exhaust air energy recovery and sound attenuation sections. Each unit has the following design specifications:

- Supply flow of 4,500 CFM
- AHRI net cooling capacity 144,000 btu/h
- 11.5 EER
- Gross cooling capacity at AHRI is 151,000 btu/h
- Supply and return fan BHP at design conditions for each unit are 2.8 and 1.1, respectively.
- Flow rate across the return fan is 90% of supply flow.
- Each thermal block also includes a restroom with a 200 CFM continuously running exhaust fan with a 75W motor (~1/10 HP).

What should be modeled for the baseline and proposed fan power?

Relative Performance – Baseline

Fan Power Example

Answer: The baseline will be modeled as follows:

According to Table G3.1.1-3, the baseline is System 3, Packaged Single Zone with Fossil Fuel Furnace.

Baseline thermal blocks are the same as in the Proposed Design.

Table G3.1.1-3 Baseline HVAC System Types

Building Area Types ^a , Number of Stories ^b , and Combined Floor Area ^c	Climate Zones 3B, 3C, and 4 to 8	Clin
Residential	System 1—PTAC	5
Public assembly area smaller than 120,000 ft ²	System 3—PSZ-AC	S ₃
Public assembly area equal to or larger than 120,000 ft ²	System 12—SZ-CV-HW	Syst
Heated-only storage	System 9—Heating and ventilation	System 10
Retail in a building that is 1 or 2 stories	System 3—PSZ-AC	S ₃
Hospital that is either • larger than 150,000 ft ² or • in a building greater than 5 stories.	System 7—EAV with reheat	System
Hospital—all other	System 5—Packaged VAV with reheat	System 5—
Other Nonresidential area that is both • smaller than 25,000 ft ² and • in a building 3 stories or fewer.	System 3—PSZ-AC	S ₃
Other Nonresidential area that is both • smaller than 25,000 ft ² and • in a building with 4 or 5 stories.	System 5—Packaged VAV with reheat	System 6—
Other nonresidential area that is both • 25,000 ft ² to 150,000 ft ² and • in a building that is 5 stories or fewer.	System 5—Packaged VAV with reheat	System 6—
Other Nonresidential area that is either • larger than 150,000 ft ² or • in a building greater than 5 stories.	System 7—EAV with reheat	System 8

a. Building area type determined in accordance with Section G3.2.1.1.
b. The total number of stories in a building, including above-grade and below-grade stories but not including stories solely devoted to parking.
c. Combined gross conditional floor area and semi-enclosed floor area, of the building area type, based on the requirements of Section G3.2.1.1.

Relative Performance – Baseline

Question: A 10,000 ft² 1-story office building has three thermal blocks, each served by a packaged heat pump.

G3.1.2.9 System Fan Power

System fan electrical power for supply, return, exhaust, and relief (excluding power to fan-powered VAV boxes) shall be calculated using the following formulas:

For Systems 1 and 2,

$$P_{fan} = CFM_s \times 0.3$$

For Systems 3 through 8, and 11, 12, and 13,

$$P_{fan} = bhp \times 746 / \text{fan motor efficiency}$$

For Systems 9 and 10 (supply fan),

$$P_{fan} = CFM_s \times 0.3$$

For Systems 9 and 10 (non-mechanical cooling fan if required by Section G3.1.2.8.2),

$$P_{fan} = CFM_{nmc} \times 0.054$$

where

P_{fan} = electric power to fan motor, W
bhp = brake horsepower of baseline fan motor from Table G3.1.2.9

fan motor efficiency = the efficiency from Table G3.9.1 for the next motor size greater than the bhp

CFM_s = the baseline system maximum design supply fan airflow rate, cfm

CFM_{nmc} = the baseline non-mechanical cooling fan airflow, cfm

G3.1.2.9.1

The calculated system fan power shall be distributed to supply, return, exhaust, and relief fans in the same proportion as the proposed design.

Table G3.1.2.9 Baseline Fan Brake Horsepower

Baseline Fan Motor Brake Horsepower	Variable-Volume Systems 3, 4, 12, and 13	Variable-Volume Systems 5 to 8	Variable-Volume System 11
CFM _s × 0.00094 + A	CFM _s × 0.0013 + A	CFM _s × 0.00062 + A	

Notes:

1. Where A is calculated according to Section 6.5.3.1.1 using the pressure-drop adjustment from the proposed design and the design flow rate of the baseline building system.
2. Do not include pressure-drop adjustments for evaporative coolers or heat recovery devices that are not required in the baseline building system by Section G3.1.2.10.

Table 6.5.3.1-2 Fan Power Limitation Pressure Drop Adjustment

Device	Adjustment
Credits	
Return or exhaust systems required by code or accreditation standards to be fully ducted, or systems required to maintain air pressure differentials between adjacent rooms.	0.5 in. of water (2.15 in. of water for laboratory and vivarium systems)
Return and/or exhaust airflow control devices	0.5 in. of water
Exhaust filters, scrubbers, or other exhaust treatment	The pressure drop of device calculated at fan system design condition
Particulate Filtration Credit: MERV 9 through 12	0.5 in. of water
Particulate Filtration Credit: MERV 13 through 15	0.9 in. of water
Particulate Filtration Credit: MERV 16 and greater and electronically enhanced filters	Pressure drop calculated at 2x clean filter pressure drop at fan system design condition
Carbon and other gas-phase air cleaners	Clean filter pressure drop at fan system design condition
Biosafety cabinet	Pressure drop of device at fan system design condition
Energy recovery device, other than coil runaround loop	For each airstream [(2.2 x Enthalpy Recovery Ratio) - 0.5] in. of water
Sound attenuation section (fans serving spaces with design background noise goals below NC35)	0.15 in. of water

Table G3.9.1 Performance Rating Method Motor Efficiency Requirements

Shaft Input Power	Full-Load Motor Efficiency for Modeling, %
1.0	82.5
1.5	84.0
2.0	84.0
3.0	87.5
5.0	87.5
7.5	89.5
10.0	89.5

Table G3.1.2.9 Baseline Fan Brake Horsepower

Baseline Fan Motor Brake Horsepower		
Constant-Volume Systems 3, 4, 12, and 13	Variable-Volume Systems 5 to 8	Variable-Volume System 11
$CFM_s \times 0.00094 + A$	$CFM_s \times 0.0013 + A$	$CFM_s \times 0.00062 + A$

Notes:
 1. Where A is calculated according to Section 6.5.3.1.1 using the pressure-drop adjustment from the proposed design and the design flow rate of the baseline building system.
 2. Do not include pressure-drop adjustments for evaporative coolers or heat recovery devices that are not required in the baseline building system by Section G3.1.2.10.

Fan Power Example

Answer Continued: To calculate baseline fan power, first determine the total baseline fan power allowance according to section G3.1.2.9. The specified units include MERV 13 filters, exhaust air energy recovery, fully ducted return and sound attenuation that each have fan power pressure drop adjustments available in 90.1 Table 6.5.3.1-2. The return is not required by code to be fully ducted, thus the associated pressure drop adjustment cannot be used for the baseline. Exhaust air energy recovery pressure drop adjustment also cannot be used because the baseline system is modeled without exhaust air energy recovery following G3.1.2.10. Only the MERV 13 adjustment (0.9) and sound attenuation adjustments (0.15) are used as follows:

$$A = (0.9 + 0.15) \times 4,850 \text{ (CFM based on sizing runs)} \div 4,131 = 1.23$$

$$\text{BHP} = 0.00094 \times \text{CFM} + A = 0.00094 \times 4,850 + 1.23 = 5.8 \text{ bhp}$$

Fan motor efficiency for the next available motor size in Table G3.9.1 is 89.5%. Based on this, the fan power is calculated as follows:

$$P_{\text{FAN}} = \text{BHP} \times 746 \div \text{Fan Motor Efficiency} = 5.8 \times 746 \div 0.895 = 4,834 \text{ W}$$

Relative Performance – Baseline

Fan Power Example

Answer Continued: The final step in determining baseline fan power is to apportion the total system PFAN to supply, return, and exhaust fans in the same proportion as in the Proposed Design. For this example, total proposed fan BHP for each system is $2.8 + 1.1 + (75/746) = 4 \text{ BHP}$. Total baseline fan power = 4,834 W. Application ratios and their usage in calculating power per unit flow for this example are listed in the table below.

	P% of Total Fan Power in Proposed Design	Total Baseline Fan Power W	Baseline Fan Power kW
Supply Fan	$2.8 / 4 = 0.7$	4,834	$0.7 * 4,834 = 3.38$
Return Fan	$1.1 / 4 = 0.275$		$0.275 * 4,834 = 1.33$
Bathroom Exhaust	$(75 / 746) / 4 = 0.025$		$0.025 * 4,834 = 0.121$

The baseline kW/CFM should either be entered directly into the modeling tool, or first converted into TSP and efficiency fraction inputs using Equation 5 from the guidelines.

Relative Performance – Baseline

Fan Power Example

Answer Continued: The final step in determining baseline fan power is to apportion the total system PFAN to supply, return, and exhaust fans in the same proportion as in the Proposed Design. For this example, total proposed fan BHP for each system is $2.8 + 1.1 + (75/746) = 4$ BHP. Total baseline fan power = 4,834 W. Application ratios and their usage in calculating power per unit flow for this example are listed in the table below.

	P% of Total Fan Power in Proposed Design	Total Baseline Fan Power W	Baseline Fan Power kW
Supply Fan	$2.8 / 4 = 0.7$	4,834	$0.7 * 4,834 * (1/1000) = 3.38$
Return Fan	$1.1 / 4 = 0.275$		$0.275 * 4,834 (1/1000) = 1.33$
Bathroom Exhaust	$(75 / 746) / 4 = 0.025$		$0.025 * 4,834 (1/1000) = 0.121$

The baseline kW/CFM should either be entered directly into the modeling tool, or first converted into TSP and efficiency fraction inputs using Equation 5 from the guidelines.

Proposed fan can be calculated for the supply and return fans by dividing the BHP by the fan motor efficiency and multiplying by 0.746 to arrive at kW.

Relative Performance – Baseline

Ventilation Demand-Controlled Ventilation (DCV)

Section 90.1 G3.1.2.5 Exception 1 requires that demand-controlled ventilation (DCV) be modeled in the baseline design for systems serving areas with a design occupancy greater than 100 people per 1,000 ft² of floor area and a design outdoor airflow greater than 3000 CFM. In all other cases, DCV is not modeled in the baseline.

DCV can be modeled for performance credit when it is not already required to be modeled per ASHRAE 90.1 2019 Appendix G. Minimum code-required ventilation rates must be used in the baseline model for systems in the proposed design claiming credit for using DCV.

Relative Performance – Baseline

Quiz #28

Question: Can credit be modeled for demand-controlled ventilation?

Proposed Design: Every other floor in a building includes DOAS air handlers with 8,000 cfm of OSA controlled by demand-controlled ventilation, the average design occupant density is 110 people per 1000 ft².

Baseline: System 7 VAV, one system per with 4,000 cfm of OSA each.

- A. Yes
- B. No

Relative Performance – Baseline

Quiz #28

Question: Can credit be modeled for demand-controlled ventilation?

Proposed Design: Every other floor in a building includes DOAS air handlers with 8,000 cfm of OSA controlled by demand-controlled ventilation, the average design occupant density is 110 people per 1000 ft².

Baseline: System 7 VAV, one system per with 4,000 cfm of OSA each.

- A. Yes
- B. **No**, both designs should be modeled with DCV. If the design OA airflow of the system in question was less than or equal to 3,000 CFM or the average design occupant density was 100 people per 1000 ft² or less, then DCV would only be modeled in the proposed case and credit could be taken.

Relative Performance – Baseline

G3.1.2.5 Ventilation

Minimum *ventilation system outdoor air* intake flow shall be the same for the *proposed design* and *baseline building design*.

Exception to G3.1.2.5

1. When modeling *demand control ventilation* in the *proposed design* in systems with *outdoor air* capacity less than or equal to 3000 cfm serving areas with an average *design capacity* of 100 people per 1000 ft² or less.

Special Rules for Laboratory Exhaust Systems



The requirements of 90.1 Appendix G for modeling the baseline laboratory exhaust systems are summarized below.

- Following Addendum ab Section G3.1.1.2 (b), laboratory spaces in buildings having a total laboratory exhaust rate greater than 15,000 CFM must be modeled with baseline systems of type 5 or 7 serving all such spaces. The lab exhaust fan must be modeled as constant horsepower (kilowatts) reflecting constant-volume stack discharge with outdoor air bypass.
- Following the exception to Section G3.1.3.13, the baseline systems serving laboratory spaces shall be modeled to reduce the exhaust and makeup air volume during unoccupied periods to the largest of 50% of zone peak air flow, the minimum outdoor air flow rate, or the air flow rate required to comply with applicable codes or accreditation standards. If project has a minimum flow rate above 50% due to the applicable codes and standards, and this higher rate is modeled in the baseline, the flow cannot be reduced below this required minimum in the proposed design.
- Following Section G3.1.2.10 Exception 2, exhaust air energy recovery does not have to be modeled in the baseline unless it is specified for the proposed design.
- Following 90.1 2019 Addendum i, HVAC systems serving laboratory HVAC zones with a total laboratory exhaust volume greater than 15,000 cfm should not be modeled with exhaust air energy recovery. Prior to the addendum, a proposed laboratory design with variable flow exhaust and energy recovery would be required to model both heat recovery and variable exhaust in the baseline HVAC system, which misrepresents 90.1 2004 requirements.

Relative Performance – Baseline

Chiller Performance Curves

Table G3.5.2 prescribes full load efficiency (FL) and part load efficiency (IPLV) for the baseline chillers depending on chiller type and capacity. Commonly used simulation tools allow entering chiller full load efficiency and performance curves that determine chiller operation at lower loads, but do not use the IPLV input. Previously, performance curves corresponding to the prescribed baseline chiller IPLV were not provided in 90.1. As a result, modelers often used default curves that differed between simulation tools and did not reflect the intended performance of the baseline chillers. The issue was addressed by [90.1 2019 addendum bd](#) which prescribed the performance curves that must be used for the baseline chillers. The addendum also prescribes chiller minimum part-load ratio (ratio of load to available capacity at a given simulation time step) and minimum compressor unloading ratio (part-load ratio below which the chiller capacity cannot be reduced by unloading and chiller is false loaded) of 0.25. [Chiller performance must be modeled as required in 90.1 2019 addendum bd.](#)

Relative Performance – Baseline

Boiler Performance Curves

Where baseline HVAC system types include boilers, boilers must be natural draft with efficiency determined based on Table G3.5.6. Number of boilers depends on the building area served by the hot water plant (Section G3.1.3.2). Boilers must be staged as required by load and modeled with 180°F supply and 130°F return water temperature (G3.1.3.3).

Atmospheric boiler performance curves included in Annex B of the guidelines must be modeled for the baseline design

Relative Performance – Baseline



Service Water Heating

90.1 Mandatory Requirements

Equipment must be sized in accordance with manufacturer's published guidelines or generally accepted engineering standards (7.4.1).

Equipment efficiencies must meet requirements in Table 7.8. Where multiple criteria are listed, all must be met (7.4.2).

Table 7.8 Performance Requirements for Water-Heating Equipment—Minimum Efficiency Requirements

Equipment Type	Size Category (Input)	Subcategory or Rating Condition	Performance Required ^a	Test Procedure ^{b,c}
Electric table-top water heaters	≤12 kW	<4000 (Btu/h)/gal ≥20 gal and ≤120 gal	For applications outside U.S., see footnote (h). For U.S. applications, see footnote (g).	10 CFR 430 Appendix E
Electric storage water heaters	≤12 kW	<4000 (Btu/h)/gal ≥20 gal and ≤55 gal	For applications outside U.S., see footnote (h). For U.S. applications, see footnote (g).	10 CFR 430 Appendix E
		<4000 (Btu/h)/gal >55 gal and ≤120 gal	For applications outside U.S., see footnote (h). For U.S. applications, see footnote (g).	10 CFR 430 Appendix E
	>12 kW ^e	<4000 (Btu/h)/gal	SL ≤ 0.3 + 27/V _m %/h	10 CFR 431.106
Electric instantaneous water heaters	≤12 kW	≥4000 (Btu/h)/gal <2 gal	For applications outside US, see footnote (h). For US applications, see footnote (g).	10 CFR 430 Appendix E
	>12 kW and ≤58.6 kW ^c	≥4000 (Btu/h)/gal ≤2 gal ≤180°F	Very Small DP: UEF = 0.80 Low DP: UEF = 0.80 Medium DP: UEF = 0.80 High DP: UEF = 0.80	10 CFR 430 Appendix E
	≤58.6 kW ^c	≥4000 (Btu/h)/gal <10 gal ≥4000 (Btu/h)/gal ≥10 gal	No requirement No requirement	

90.1 Mandatory Requirements



Service hot water pipe insulation must meet the minimum specified levels (7.4.3).

SWH system controls (7.4.4)

- Temperature controls to allow adjusting temperature from 120F or lower to a maximum temperature compatible with intended use.
- Systems designed to maintain usage temperatures in hot water pipes, such as recirculating systems or heat trace, must be equipped with automatic time switched or other controls to switch off the system during extended periods when hot water is not required.
- Controls to limit the maximum temperature of water delivered from lavatory faucets in public restrooms to 110°F
- Circulating pump controls used to maintain storage tank water temperature must be equipped with controls limiting operation when not needed.

Table 6.8.3-1 Minimum Piping Insulation Thickness Heating and Hot Water Systems^{a,b,c,d,e} (Steam, Steam Condensate, Hot-Water Heating and Domestic Water Systems)

Fluid Operating Temperature Range (°F) and Usage	Insulation Conductivity		≥Nominal Pipe or Tube Size, in.			
	Conductivity, Btu-in/h-ft ² -°F	Mean Rating Temperature, °F	<1	1 to <1-1/2	1-1/2 to <4	4 to <6
>350	0.32 to 0.34	250	4.5	5.0	5.0	5.0
251 to 350	0.29 to 0.32	200	3.0	4.0	4.5	4.5
201 to 250	0.27 to 0.30	150	2.5	2.5	2.5	3.0
141 to 200	0.25 to 0.29	125	1.5	1.5	2.0	2.0
105 to 140	0.22 to 0.28	100	1.0	1.0	1.5	1.5

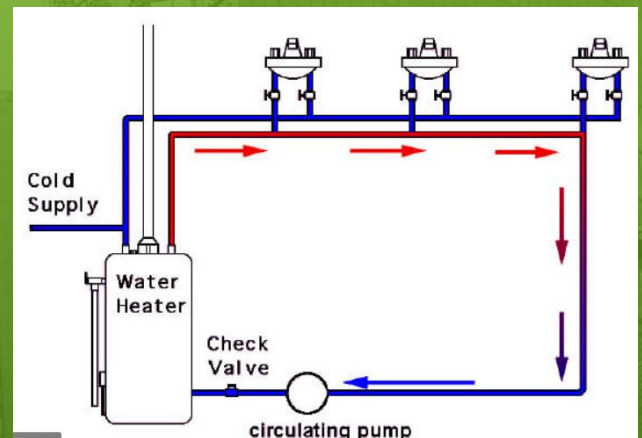

90.1 Mandatory Requirements (Continued)

- Requirements for heated pools including pool covers, heater on/off switch, and time switches on pool heaters and pumps (7.4.5).
- Heat traps on inlet and outlet vertical pipe risers serving storage water heaters and storage tanks not having integral heat traps and serving a nonrecirculating system, to counteract the natural convection of heated water in a vertical pipe run (7.4.6).

Table 6.8.3-1 Minimum Piping Insulation Thickness Heating and Hot Water Systems^{a,b,c,d,e}
(Steam, Steam Condensate, Hot-Water Heating and Domestic Water Systems)

Fluid Operating Temperature Range (°F) and Usage	Insulation Conductivity		≥Nominal Pipe or Tube Size, in.			
	Conductivity, Btu-in/h-ft ² -°F	Mean Rating Temperature, °F	<1	1 to <1-1/2	1-1/2 to <4	4 to <6
>350	0.32 to 0.34	250	4.5	5.0	5.0	5.0
251 to 350	0.29 to 0.32	200	3.0	4.0	4.5	4.5
201 to 250	0.27 to 0.30	150	2.5	2.5	2.5	3.0
141 to 200	0.25 to 0.29	125	1.5	1.5	2.0	2.0
105 to 140	0.22 to 0.28	100	1.0	1.0	1.5	1.5

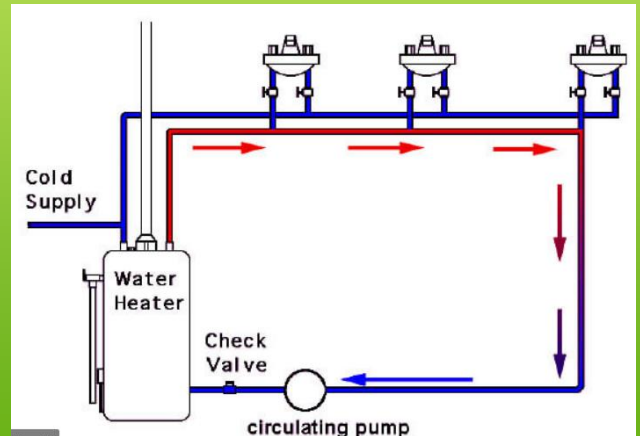

Service Water Heating: Proposed Design

Modeling Requirements Water Heating Systems

New Systems

- Where a service water-heating system has been designed, the service water-heating model must be consistent with design documents.

Existing Systems

- Where a complete service water-heating system exists, the model must reflect the actual system type using actual component capacities and efficiencies.

Where no service water-heating system exists or is specified

- No service water-heating system must be modeled for buildings that will have no service water-heating loads.
- In other cases, the same service water-heating system type serving the same water heating loads must be modeled as in the baseline design, but with equipment efficiencies minimally compliant with requirements in Section 7.

Losses from service hot water distribution piping not modeled



Relative Performance –
Proposed



Modeling Requirements Hot Water Demand Savings

How water demand may be lower than in the baseline if the following technologies are specified (Exceptions 1-3 to Table G3.1 #11 (g), Baseline Building Performance column):

- Measures that reduce the physical volume of service water required below the maximum flow rates allowed by applicable code, such as low-flow shower heads and dishwashers.
- Measures that reduce the required temperature of service mixed water or that reduce the hot fraction of mixed water required. Examples include alternative sanitizing technologies for dishwashing and shower or laundry heat recovery to incoming cold-water supply.

In all cases, the supporting calculations justifying the modeled reduction in hot water demand must be included in submittal and are subject to AHJ approval.

Relative Performance – Proposed

Modeling Requirements

Hot Water Demand Savings Example

Technologies demonstrating a reduction in hot water usage should be modeled as reduced hot water demand in the Proposed Design based on Equation 6 from the guidelines.

Equation 6:

$$HWD_{PROP} = HWD_{BASE} * (1 - R)$$

Equation 7:

$$R = \sum (R_A * F_A)$$

Where:

HWD_{BASE} = baseline consumption [gal/day]

R = % reduction from baseline to proposed.

R_A = % reduction in hot water usage for a particular hot water application

F_A = hot water usage for the particular application as a fraction of total usage.

Table 5: FA and RA values for calculating reductions in hot water usage

Load Type	F_A^*	R_A	Notes
Low flow faucets	Residential: 10% Commercial : estimate	1- FR/MAF	FR = average flow rate of installed faucets (GPM); MAF= maximum allows flow rate based on 2021 International Plumbing Code Table 604.3 MAF=0.8 for private lavatories MAF=0.5 for public lavatories MAF=1.75 for other residential sinks (e.g. kitchen) MAF=3 for service sinks
Low flow showerheads	Residential: 54% Commercial : estimate	1- FR/2.5	FR = average flow rate of installed showerheads (GPM); 2.5 GPM = From Table 604.3
Energy Star Appliances	$\frac{APPL_{BASE}}{HWD_{BASE}}$	WS	$APPL_{BASE}$ = Baseline water usage for the appliance from the Energy Star Calculator, in the same units as HWD_{BASE} ; WS = % Water Savings from the Energy Star Calculator

*sum of all FA values must not exceed 100%

Relative Performance – Proposed

Modeling Requirements

Hot Water Demand Savings Example

Question: The baseline hot water demand for a multifamily project is 4,280 gallons (HWD_{BASE}). The project team has specified showerheads at 1.75 GPM. All other specified plumbing fixtures align with the requirements of the 2021 International Plumbing Code. What hot water demand should be modeled in the proposed?

Relative Performance – Proposed



Modeling Requirements

Hot Water Demand Savings Example

Answer:

$$HWD_{PROP} = HWD_{BASE} * (1-R)$$

$$HWD_{PROP} = 4,280 * (1-R)$$

$$R = \sum(R_A * F_A)$$

$$F_A = 54\%$$

$$R_A = 1 - 1.75/2.5 = 0.3 * 100\% = 30\%$$

$$R = (30\% * 54\%) = 16.2\%$$

$$HWD_{PROP} = 4,280 * (1-16.2\%) = 3,587 \text{ gallons per day}$$

Table 5: FA and RA values for calculating reductions in hot water usage

Load Type	F _A *	R _A	Notes
Low flow faucets	Residential: 10% Commercial : estimate	1-FR/MAF	FR = average flow rate of installed faucets (GPM); MAF= maximum allows flow rate based on <u>2021 International Plumbing Code Table 604.3</u> MAF=0.8 for private lavatories MAF=0.5 for public lavatories MAF=1.75 for other residential sinks (e.g. kitchen) MAF=3 for service sinks
Low flow showerheads	Residential: 54% Commercial : estimate	1-FR/2.5	FR = average flow rate of installed showerheads (GPM); 2.5 GPM = From Table 604.3
Energy Star Appliances	$\frac{APP_{LBASE}}{HWD_{BASE}}$	WS	APPL _{BASE} = Baseline water usage for the appliance from the Energy Star Calculator, in the same units as HWD _{BASE} ; WS = % Water Savings from the Energy Star Calculator

Relative Performance – Proposed



Service Water Heating: Baseline Design

Modeling Requirements System and Demand

- The service hot-water system in the baseline building design is prescribed in Table G3.1.1-2 and is either gas or electric resistance storage central water heater. In mixed use buildings, baseline water heater type must be established separately for each occupancy.
- Hot water demand in the Baseline Building Design must be typical for building occupancy type. Table 4 in the guidelines provides typical hot water use for various types of buildings that should be used to establish baseline hot water energy use. 2019 ASHRAE Applications Handbook also provides hot water demand per fixture for various types of buildings which may be used to establish appropriate assumptions.

Table G3.1.1-2 Baseline Service Water-Heating System

Building Area Type	Baseline Heating Method	Building Area Type	Baseline Heating Method
Automotive facility	Gas storage water heater	Performing arts theater	Gas storage water heater
Convenience store	Electric resistance storage water heater	Police station	Electric resistance storage water heater
Convention center	Electric resistance storage water heater	Post office	Electric resistance storage water heater
Courthouse	Electric resistance storage water heater	Religious facility	Electric resistance storage water heater
Dining: Bar lounge/leisure	Gas storage water heater	Retail	Electric resistance storage water heater
Dining: Cafeteria/fast food	Gas storage water heater	School/university	Gas storage water heater
Dining: Family	Gas storage water heater	Sports arena	Gas storage water heater
Dormitory	Gas storage water heater	Town hall	Electric resistance storage water heater
Exercise center	Gas storage water heater	Transportation	Electric resistance storage water heater
Fire station	Gas storage water heater	Warehouse	Electric resistance storage water heater
Grocery store	Gas storage water heater	Workshop	Electric resistance storage water heater
Gymnasium	Gas storage water heater	All others	Gas storage water heater
Health-care clinic	Electric resistance storage water heater		
Hospital and outpatient surgery center	Gas storage water heater		
Hotel	Gas storage water heater		
Library	Electric resistance storage water heater		
Manufacturing facility	Gas storage water heater		
Motel	Gas storage water heater		
Motion picture theater	Electric resistance storage water heater		
Multifamily	Gas storage water heater		
Museum	Electric resistance storage water heater		
Office	Electric resistance storage water heater		
Parking garage	Electric resistance storage water heater		
Penitentiary	Gas storage water heater		

Relative Performance – Baseline

Modeling Requirements Hot Water Demand

Sample Hot-Water Demands and Use for Various Types of Buildings^{1*}
(Table 4 from the guidelines)

Type of Building	Average Daily Usage
Dormitories**	12.7 Gal/Student
Motels***	
20 units or less	20 Gal/Unit
20-100 units	14 Gal/Unit
100 units or more	10 Gal/Unit
Nursing Homes	18.4 Gal/Bed
Office Buildings	1.0 Gal/Person
Food Service Establishments	
Type A: Full Meal Restaurants and Cafeterias	2.4 Gal/Average meals/day
Type B: Drive-ins, Grills, Luncheonettes, Sandwich, and Snack Shops	0.7 Gal/Average meals/day
Apartments****	39 Gal/Apartment
Elementary schools	0.6 gal/student
Junior and senior high school	1.8 gal/student

*Data predates modern low-flow fixtures and appliances, and may be reduced by projects

**Average of men's and women's dormitories

***Categories changed to ranges to avoid the need for interpolation

****Average for different size apartment buildings

1. Based on 2019 ASHRAE Applications Handbook, Section 51, Table 6

Relative Performance – Baseline

Quiz #29

Question: How many and what service water heater type(s) should be modeled for a 10-story mixed use building with multifamily on floors 3-10 and retail occupying floors 1 and 2? The proposed design includes a heat pump water heater with storage that is designed to serve the entire building.

- A. Same number and type as the proposed.
- B. One gas storage water heater serving the entire building.
- C. One gas storage water heater serving the multifamily portion and one electric resistance storage water heating serving the retail.
- D. One electric storage water heater serving the entire building.

Table G3.1.1-2 Baseline Service Water-Heating System

Building Area Type	Baseline Heating Method	Building Area Type	Baseline Heating Method
Automotive facility	Gas storage water heater	Performing arts theater	Gas storage water heater
Convenience store	Electric resistance water heater	Police station	Electric resistance storage water heater
Convention center	Electric resistance storage water heater	Post office	Electric resistance storage water heater
Courthouse	Electric resistance storage water heater	Religious facility	Electric resistance storage water heater
Dining: Bar lounge/leisure	Gas storage water heater	Retail	Electric resistance storage water heater
Dining: Cafeteria/fast food	Gas storage water heater	School/university	Gas storage water heater
Dining: Family	Gas storage water heater	Sports arena	Gas storage water heater
Dormitory	Gas storage water heater	Town hall	Electric resistance storage water heater
Exercise center	Gas storage water heater	Transportation	Electric resistance storage water heater
Fire station	Gas storage water heater	Warehouse	Electric resistance storage water heater
Grocery store	Gas storage water heater	Workshop	Electric resistance storage water heater
Gymnasium	Gas storage water heater	All others	Gas storage water heater
Health-care clinic	Electric resistance storage water heater		
Hospital and outpatient surgery center	Gas storage water heater		
Hotel	Gas storage water heater		
Library	Electric resistance storage water heater		
Manufacturing facility	Gas storage water heater		
Motel	Gas storage water heater		
Motion picture theater	Electric resistance storage water heater		
Multifamily	Gas storage water heater		
Museum	Electric resistance storage water heater		
Office	Electric resistance storage water heater		
Parking garage	Electric resistance storage water heater		
Penitentiary	Gas storage water heater		

Quiz #29

Question: How many and what service water heater type(s) should be modeled for a 10-story mixed use building with multifamily on floors 3-10 and retail occupying floors 1 and 2? The proposed design includes a heat pump water heater with storage that is designed to serve the entire building.

- A. Same number and type as the proposed.
- B. One gas storage water heater serving the entire building.
- C. One gas storage water heater serving the multifamily portion and one electric resistance storage water heating serving the retail.
- D. One electric storage water heater serving the entire building.

Table G3.1.1-2 Baseline Service Water-Heating System

Building Area Type	Baseline Heating Method	Building Area Type	Baseline Heating Method
Automotive facility	Gas storage water heater	Performing arts theater	Gas storage water heater
Convenience store	Electric resistance water heater	Police station	Electric resistance storage water heater
Convention center	Electric resistance storage water heater	Post office	Electric resistance storage water heater
Courthouse	Electric resistance storage water heater	Religious facility	Electric resistance storage water heater
Dining: Bar lounge/leisure	Gas storage water heater	Retail	Electric resistance storage water heater
Dining: Cafeteria/fast food	Gas storage water heater	School/university	Gas storage water heater
Dining: Family	Gas storage water heater	Sports arena	Gas storage water heater
Dormitory	Gas storage water heater	Town hall	Electric resistance storage water heater
Exercise center	Gas storage water heater	Transportation	Electric resistance storage water heater
Fire station	Gas storage water heater	Warehouse	Electric resistance storage water heater
Grocery store	Gas storage water heater	Workshop	Electric resistance storage water heater
Gymnasium	Gas storage water heater	All others	Gas storage water heater
Health-care clinic	Electric resistance storage water heater		
Hospital and outpatient surgery center	Gas storage water heater		
Hotel	Gas storage water heater		
Library	Electric resistance storage water heater		
Manufacturing facility	Gas storage water heater		
Motel	Gas storage water heater		
Motion picture theater	Electric resistance storage water heater		
Multifamily	Gas storage water heater		
Museum	Electric resistance storage water heater		
Office	Electric resistance storage water heater		
Parking garage	Electric resistance storage water heater		
Penitentiary	Gas storage water heater		

A blue-tinted background image showing a person's hands holding a white sign that reads "WELCOME WE ARE OPEN PLEASE COME IN".

Special Cases

Core and Shell

Core and shell projects include designs where only the envelope is completed, and the mechanical, lighting, and other interior systems are either incomplete or partially complete at the time of building permitting.

Core and Shell Proposed

- Systems and components that are not specified on construction documents must be modeled as minimally complying with ASHRAE Standard 90.1 2019 in the proposed design.
- Modeling the proposed design based on the efficiency of systems required by lease is not permitted.
- When the shared heating, cooling and service water heating systems are specified but the terminal systems in the tenant spaces are not, the tenant systems of the appropriate type that minimally comply with ASHRAE Standard 90.1 2019 shall be modeled.
- When the proposed design includes plumbing fixtures but not the service water heater, the proposed design model must reflect requirements in Table G3.1, row #11 Service Water Heating Systems as follows:
 - The proposed water heater shall be modeled as described in the Proposed Building Performance column item (c)
 - Savings from reduced service water heating load are permitted to be modeled as allowed in the Baseline Building Performance column Exceptions (1) and (2)

Core and Shell Baseline

The baseline design must be modeled following the same rules as when all components are fully specified.

Tenant Space Fit Out Zones

When core and shell areas are leased out for the first time and design documents for mechanical, lighting and other systems are submitted for building permit, the project must meet the same requirements as a new construction project (C401.2).

Tenant Space Fit Out Zones Proposed

The proposed design models for tenant space fit out zones must reflect systems, components and controls shown on the construction documents for the tenant zone and previously designed systems included in the core-and-shell project housing the tenant area.

Tenant Space Fit Out Zones Baseline

The baseline shall be modeled the same as for new construction projects.

District Energy Systems

MA Stretch modeling requirements for district energy systems are aligned with ASHRAE 90.1 2022 Addendum A:

- The HVAC systems in the baseline design for projects served by the district systems shall be modeled the same as for projects with on-site systems.
- The proposed design is modeled with steam, chilled water or hot water supplied by an on-site virtual chiller, boiler plant and/or water heater that complies with but does not exceed the applicable mandatory and prescriptive requirements in 90.1 2022 Section 6.

Electricity Generation Systems

- Contribution of renewable electricity generation systems toward compliance with Section C407.2 is not allowed following MA Stretch amendments to 90.1 Section G2.4.1. Such systems should not be modeled in either the proposed design or baseline design.
- Combined Heat and Power systems must be modeled the same in the baseline and proposed design, except the baseline design must be modeled without waste heat recovery (90.1 G2.4.2).

Example: Modeling Combined Heat and Power Systems

Question: A hospital project includes a combined heat and power (CHP) system that uses natural gas to generate electricity. The waste heat from the CHP is recovered and used for service water heating. How should the CHP be modeled in the baseline and proposed design?

Answer: In the proposed design, CHP must be modeled as specified, reflecting the specified system electric and thermal efficiency and controls.

In the baseline design, CHP must be modeled based on the specified electricity generation efficiency but without accounting for the recovered heat. Service hot water would be supplied by the gas storage water heater (90.1 Table G3.1.1-2).

Quiz #30

Question: A hospital project includes a combined heat and power (CHP) system that uses natural gas to generate electricity. The waste heat from the CHP is recovered and used for service water heating. How should the CHP be modeled in the baseline and proposed design?

- A. As-design in proposed. In the baseline design, the CHP would be modeled as part of the whole building simulation reflecting the electricity generation efficiency but without accounting for the recovered heat. Service hot water would be provided by the gas storage water heater per 90.1 Table G3.1.1-2.
- B. Identical in the baseline and proposed.

Quiz #30

Answer: A In the proposed design, the CHP would be modeled as part of the whole building simulation, reflecting the specified system electric and thermal efficiency and controls

In the baseline design, the CHP would be modeled as part of the whole building simulation reflecting the electricity generation efficiency but without accounting for the recovered heat (yes, if it used gas to produce electricity the gas would be modeled in the baseline).. Service hot water would be provided by the gas storage water heater (90.1 Table G3.1.1-2).



Reporting

Reporting Requirements

Filled out DOE/PNNL [ASHRAE Standard 90.1 Performance Based Compliance Form](#) and [MA Stretch 2023 Companion Tool](#). These meeting ASHRAE 90.1 2019 reporting requirements.

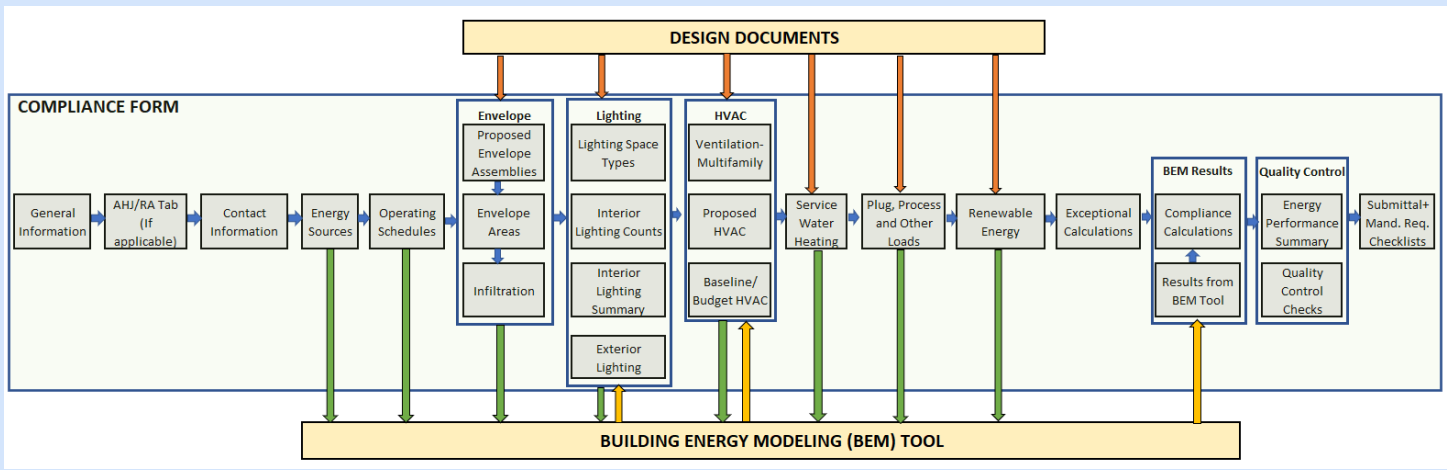

Also need to provide calculations of the average ventilation rate similar to what is required by Section C103.2 #16

Reference Materials



- [ASHRAE 90.1 2019 Users' Manual](#)
- [ASHRAE 90.1 Section 11 and Appendix G Submittal Review Manual](#) is a comprehensive reference for reviewing modeling-based submittals. The Manual is a companion to the DOE/PNNL 90.1 Section 11 and Appendix G Compliance Form and supports 2016, 201, and 2022 editions of ANSI/ASHRAE Standard 90.1. The document was developed to help code officials review modeling-based submittals and should also be used energy modelers to self-check the models before submitting compliance documentation to code official.
- [ASHRAE Standard 90.1 Performance Based Compliance Form](#) is spreadsheet-based and meets the documentation requirements of Standards 90.1-2016, 2019 and 2022 Section 11 Energy Cost Budget Method and Appendix G Performance Rating Method. It helps the modeler establish simulation inputs for the baseline/budget and proposed design models and includes a submittal checklist to ensure that all necessary supporting documentation is included in the submittal. It standardizes compliance documentations and simplifies submittal reviews by code officials and administrators of above code program implementers.
- [Massachusetts Stretch Relative Performance Path Companion Tool](#) is spreadsheet-based tool that imports data from the ASHRAE Standard 90.1 Performance Based Compliance Form to calculate MA Stretch 2023 compliance using MA Stretch BPFs and the site energy compliance metric.

Conclusion

Targeted and Relative Performance Summary

	Targeted Performance (C407.1)	Relative Performance (C407.2)
Modeling Rules	1 model developed following MA Stretch modeling guidelines	2 models developed following 90.1 2019 Appendix G with MA amendments
Approved simulation software	eQUEST, EnergyPlus, IESVE	Any BEM tool compliant with 90.1 Appendix G
Modeler Qualifications	Modelers must meet Modeler_Quals_FINAL.pdf (energycodes.gov)	
Applicable Building Types	Allowed for all, required for multifamily (after 7/1/2024), dormitory, fire station, library, office, K-12 school, police station, post office and town halls except if high ventilation	Allowed only for projects that are not required to follow the Targeted Performance path
Compliance Criteria	Modeled heating and cooling TEDIs must not exceed the set targets	Modeled PEI of the proposed design must not exceed PEI target
Systems that Affect Modeled Compliance Outcome	Envelope shape and performance, exhaust air energy recovery effectiveness.	Envelope, lighting, HVAC, SWH, other loads regulated by code
Trade-off limits	Must meet all prescriptive requirements.	Must meet 90.1 2019 mandatory requirements and certain prescriptive requirements of MA Stretch.

Modeled vs. Measured Energy Use

Post-occupancy utility bills will likely differ from the modeled performance due to the following:

- Variations in schedule of operation and occupancy
- Building operation and maintenance
- Weather (10-year historical weather average \neq 2023 weather)
- Use of prescribed simulation assumptions
- Tenant equipment
- Precision of the simulation tool and modeler mistakes

Other Relevant Trainings

Title	Target Audience	Topics covered
MA Stretch Energy Code 2023 for Commercial Buildings: Targeted Performance (TEDI) and Relative Performance (90.1 Appendix G) Compliance Paths	Code Officials & Modelers	<ul style="list-style-type: none">• Applicability• Overview of the modeling requirements• Special rules for additions, core-and-shell and retrofits• Requirements other than energy modeling
Modeling for MA Stretch TEDI and Appendix G (8 hours)	Modelers	<ul style="list-style-type: none">• Detailed modeling requirements
Compliance documentation for MA Stretch TEDI and Appendix G (2 hours)	Code Officials & Modelers	<ul style="list-style-type: none">• Reporting templates• Other materials that must be submitted

Commercial New Construction or Major Renovation Program

Choose Your Path to Generate Energy Savings and Reduce Carbon

A Pathway for Every Project

Mass Save Sponsors offer the highest incentives for projects with the lowest EUIs and greatest levels of decarbonization.

Path 1, Net Zero and Low EUI Buildings (10,000 sqft or greater)	Path 2, Whole Building Energy Use Intensity (EUI) Reduction Approach (50,000 ft ² or greater)	Path 2, High Performance Buildings
<p>Receive expert net zero building technical assistance and the highest new construction/major renovation project incentives available. Set an ultra-low EUI and save. We provide support through a post occupancy period to help you make sure the building performs at the level you expect.</p>	<p>In this path for larger, complex building projects, your incentives will be greater with the lowest design EUIs. We offer technical support and energy modeling services to help you succeed.</p>	<p>For whole building projects of any size where customers do not wish to set and pursue an EUI target, projects that are not whole buildings (e.g., tenant fit outs, open air parking garages), projects that are process-load heavy buildings (e.g., cannabis, industrial), and projects where customers are only interested in one-off measures.</p>

Energy Code Support

Questions about the energy code?



Energy Code Support Hotline:

855-757-9717



Energy Code Support Email:

energycodesma@psdconsulting.com

Thank you.

Massachusetts Energy Code Technical Support Program

WE ARE MASS SAVE®:



EVERSOURCE



nationalgrid

